

NEWCO[®]

OIC[®] Cast and Forged Stainless Steel Valves

Technical Data



TABLE OF CONTENTS

Overview.....	7
Cast Stainless Steel Gate Valves.....	9
Sizes: 1/2" to 24"	
Pressure Class: 150 to 1500	
I. Conventional Port.....	11
Sizes: 1/2" to 24"	
Classes: 150 to 1500	
II. Special Applications – Cryogenic Conventional Port.....	15
Sizes: 1/2" to 24"	
Classes: 150 to 600	
Cast Stainless Steel Globe Valves.....	17
Sizes: 1/2" to 12"	
Pressure Class: 150 to 1500	
I. Conventional Port.....	19
Sizes: 1/2" to 12"	
Classes: 150 to 1500	
II. Special Applications – Cryogenic Conventional Port.....	22
Sizes: 1/2" to 6"	
Classes: 150 to 300	
Cast Stainless Steel Check Valves.....	24
Sizes: 1/2" to 24"	
Pressure Class: 150 to 1500	
I. Swing Check Valve Conventional Port.....	26
Sizes: 1/2" to 14"	
Classes: 150 to 1500	
Forged Gate, Globe and Check Valves.....	30
Sizes: 1/4" to 2"	
Pressure Class: 800 and 1500	
I. Regular Port Gates – Socket Weld and Threaded.....	30
Sizes: 1/4" to 2"	
Classes: 800 and 1500	
II. Regular Port Globes – Socket Weld.....	32
Sizes: 1/2" to 2"	
Classes: 800 and 1500	
III. Swing Regular Port Checks – Socket Weld and Threaded.....	34
Sizes: 1/2" to 2"	
Classes: 800 and 1500	

IV. Lift Regular Port Checks – Socket Weld and Threaded	36
Sizes: 1/2" to 2"	
Classes: 800 and 1500	
Inside Diameter Dimensions	38
Full Bore: 150 to 2500	
Pressure Temperature Ratings.....	40
Valve Class: 150 to 2500	
Flange Dimensions – ASME B16.5.....	43
Class: 150 to 600	
How to Order Cameron’s NEWCO OIC Cast Products	47
How to Order Cameron’s NEWCO OIC Forged Products.....	48
Industry Standards Typically Used in Valve Manufacturing	49

OVERVIEW

Valve and I.D. Tag

The identification tag displays all construction and tracking data regarding the respective valve on which it is attached. Below is a general overview of the identification tag components.

I.D. tags are located on the bonnet.

Globe and check valves will have a flow direction arrow on body for proper installation.

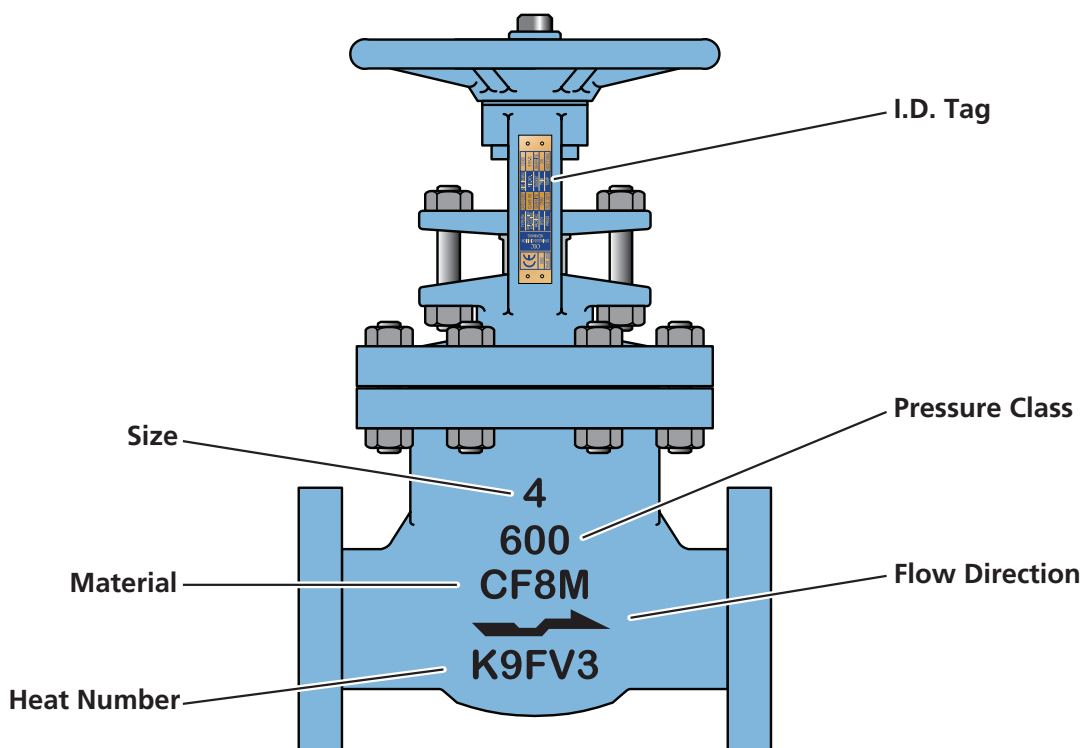

Sample NEWCO OIC I.D. Tag

 0062 YEAR: 2009	OIC STAINLESS DIVISION NEWMANS	TYPE/SN	GATE/102857	SIZE (IN/MM)	12/300
		RATING/DESIGN B16.34/API 600	CLASS 150	FIG. NO.	S151-G
		PACKING	GRAPHITE	GASKET	GRAPHITE
		BODY	CF8M	TRIM	316
		PRESS	275 @ 100°F	TEMP	1000°F MAX

Typical Bill of Materials

Component	Material	Component	Material
Gate			
Handwheel Nut	300 Series Stainless Steel	Back Set Bushing	Integral
Handwheel	Nodular Iron	Bonnet	A351-CF8M (316)
Yoke Nut	300 or 400 Series Stainless Steel	Bonnet Gasket	Graphite or PTFE or A182 GR.F316
Yoke Sleeve	A439 Gr D2C	Bonnet Nut	A194-8/8F
Stem	A276-316	Bonnet Bolt	A193-B8
Gland Eye Bolt and Nut	304SS	Body	A351-CF8M (316)
Gland Flange	CF8M	Seal Ring	Cast Integral Body
Gland	A276-316	Wedge	A351-CF8M (316)
Stem Packing	Graphite or PTFE		
Globe			
Handwheel Nut	300 Series Stainless Steel	Back Seat Bushing	Integral
Handwheel	Nodular Iron	Bonnet	A351-CF8M
Stem	A276-316	Bonnet Gasket	Graphite or PTFE or A182 GR.F316
Gland Eye Bolt and Nut	304SS	Bonnet Nut	A194-8/8F
Gland Flange	CF8M	Bonnet Bolt	A193-B8
Gland	A276-316	Body	A351-CF8M
Yoke Bushing	A439 Gr D2C	Seal Ring	Integral
Stem Packing	Graphite or PTFE	Disc	A351-CF8M (316)
Check			
Cap Bolt	A193-B8	Seat Rings	Integral
Cap Nut	A194-8/8F	Hinge	A351-CF8M
Cap	A351-CF8M	Disc Nut	A194-8/8M
Cap Gasket	Graphite/PTFE or Graphite/A182-F316	Disc Washer	A167-316
Hinge Pin	A276-316	Disc	A351-CF8M
Body	A351-CF8M		

¹PTFE (Teflon) is a registered trademark of E.I DuPont. Temperature limit 400° F (204° C).

CAST STAINLESS STEEL GATE VALVES

SIZES: 1/2" TO 24"
PRESSURE CLASS: 150 TO 1500

Typical Cameron NEWCO OIC Stainless Steel Gate Valve Expanded View

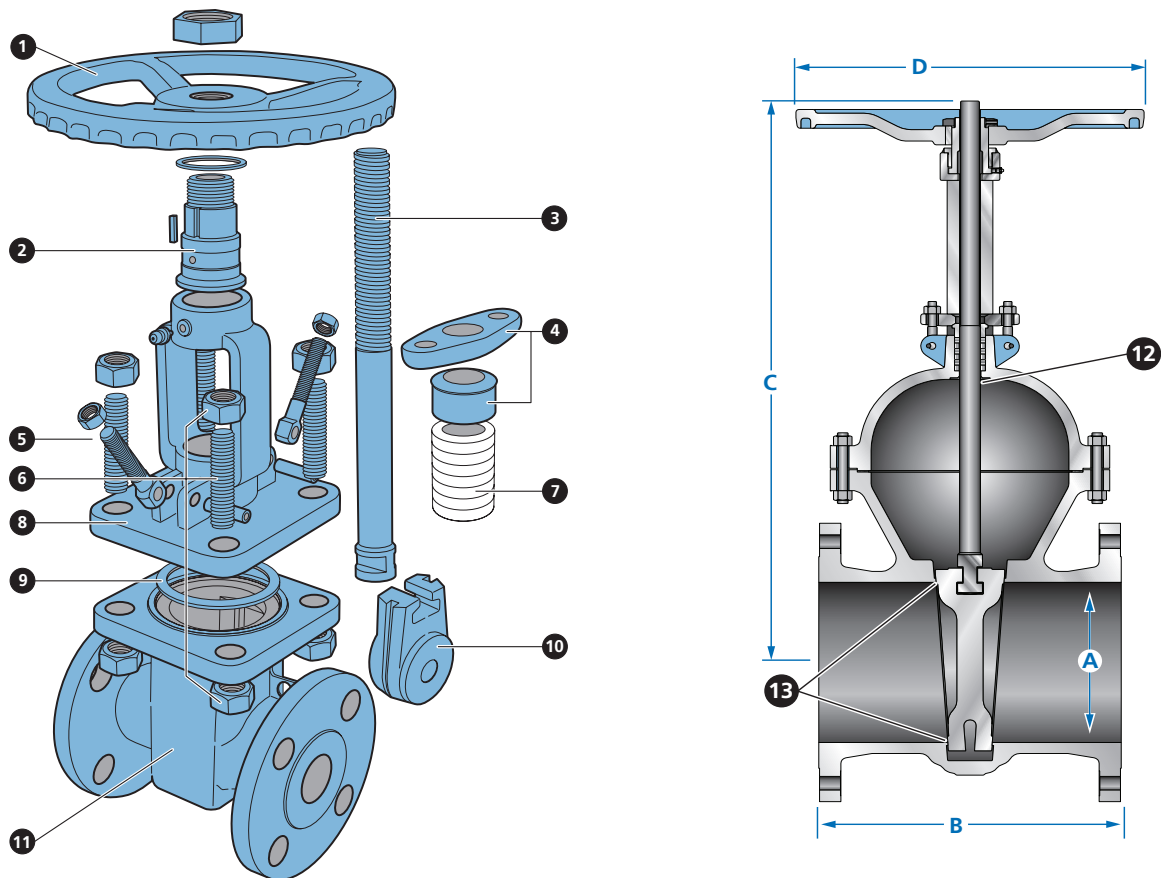

1. **Handwheel:** The nodular iron handwheels are well shaped and large enough to give ease of movement when operating the valve, even under maximum differential pressure.
2. **Yoke Sleeve:** The yoke sleeve is made from ductile iron A439 Gr D2C with a high resistance to wear and a high melting point. It is designed to permit removal from the bonnet or the yoke while the valve is in service. Gate valved 6"-600-lb class and above are fitted with a ball and thrust bearing.
3. **Stem:** The stem is stainless steel and is part of the trim. The stem is provided with a T-head. A ground backseat is provided to ensure perfectly tight seal to the stuffing box when the valve is fully open. The stem is ground to minimize friction and prevent damage to gland packing. The threading is trapezoidal ACME type. Dimensions comply with the applicable standard.
4. **Gland and Flange:** They are stainless steel and are normally supplied in two pieces. The contact surfaces between gland and gland flange have a spherical profile to permit the gland to descend parallel to the stem even if the eyebolts are not evenly tightened.

5. **Gland Bolts and Nuts:** The stainless steel gland bolts are of the eyebolt type which can be swung outward for ease of gland repacking. They are fixed to the bonnet by solid bolt pin tack welded.
6. **Bonnet Bolting:** Bonnet studs and nuts are manufactured from alloy or stainless steel to the relevant ASTM standard.
7. **Packing*:** The packing is made with die formed graphite center rings with braided graphite top and bottom rings, or with teflon.
8. **Bonnet:** The bonnet is in stainless steel. It is machined to accept the yoke sleeve and incorporate the stuffing box dimensioned in accordance with the API standard.
9. **Gasket*:** The gasket is made from graphite or teflon, as specified based on service condition requirements.
10. **Wedge:** The wedge is part of the trim, cast stainless steel or specified alloy. It is normally supplied as a flexible or solid and connected to the stem by means of a T-joint. The guides on each side of the wedge are machined for proper alignment with the body guides. Special attention is given to the seating surfaces which are round and lapped to ensure a perfectly tight seal.
11. **Body:** The body is stainless steel and is carefully designed in all its details. The basic dimensions, i.e. wall thickness, face to face and flanges, comply with the relevant API and ANSI standards. The sealing surfaces for connection to the bonnet are flat finish in the 150-lb class in sizes 1/2" - 1" and 3" and up; recessed in 1-1/2" and 2"; recessed in all sizes 300-lb and 600-lb class. Bosses may be provided for drain taps or bypass piping.
12. **Bonnet Bushing (Integral):** The bonnet bushing or backseat is integrally machined from the cast stainless steel bonnet and forms part of the trim. Special attention is given to its machining and heat treatment to insure a proper seat.
13. **Seat Rings:** The seat rings are cast integral to the body and are part of the trim. Special attention is given to the seating surfaces, which are ground and lapped for a perfectly tight seal.

* *Recommended spare parts.*

I. CONVENTIONAL PORT

SIZES: 1/2" TO 24" (15MM TO 600MM)* • CLASSES: 150 TO 1500

Design and Manufacturing Standards

Valve Design: API 603/ASME B16.34

Flange Dimensions: ASME B16.5

Face to Face Dimensions: ASME B16.10

Tested in Accordance With: API 598

Class 150					
Size NPS (DN)	A	B	C	D	Weight Lbs (Kg)
1/2	0.50	4.25	8.19	4.00	7.0
(15)	(12.7)	(108.0)	(208.0)	(101.6)	(3.2)
3/4	0.75	4.63	8.35	4.00	7.9
(20)	(19.1)	(117.6)	(212.1)	(101.6)	(3.6)
1	1.00	5.00	9.65	4.75	11.0
(25)	(25.4)	(127.0)	(245.1)	(120.7)	(5.0)
1-1/2	1.50	6.50	8.80	4.72	17.6
(40)	(38.1)	(165.1)	(223.5)	(119.9)	(8.0)
2	2.00	7.00	14.09	7.09	26.4
(50)	(50.8)	(177.8)	(357.9)	(180.1)	(12.0)
2-1/2	2.50	7.50	15.55	7.09	37.0
(65)	(63.5)	(190.5)	(395.0)	(180.1)	(17.0)
3	3.00	8.00	16.22	7.87	46.0
(80)	(76.2)	(203.2)	(412.0)	(199.9)	(21.0)
4	4.00	9.00	20.94	8.82	75.0
(100)	(101.6)	(228.6)	(531.9)	(224.0)	(34.0)
6	6.00	10.50	28.11	9.84	123.0
(150)	(152.4)	(266.7)	(714.0)	(249.9)	(56.0)
8	8.00	11.50	35.98	12.40	200.0
(200)	(203.2)	(292.1)	(913.9)	(315.0)	(91.0)
10	10.00	13.00	43.82	13.98	301.0
(250)	(254.0)	(330.2)	(1113.0)	(655.1)	(137.0)
12	12.00	14.00	51.73	15.75	449.0
(300)	(304.8)	(355.6)	(1313.9)	(400.1)	(204.0)
14	13.25	15.00	58.43	19.69	664.0
(350)	(336.6)	(381.0)	(1484.1)	(500.1)	(302.0)

Class 150					
Size NPS (DN)	A	B	C	D	Weight Lbs (Kg)
16	15.25	16.00	66.69	22.05	994.0
(400)	(387.4)	(406.4)	(1693.9)	(560.1)	(429.0)
18*	17.25	17.00	73.86	22.05	1065.0
(450)	(438.2)	(431.8)	(1876.0)	(560.1)	(484.0)
20*	19.25	18.00	83.19	24.80	1373.0
(500)	(489.0)	(457.20)	(2113.0)	(629.9)	(624.0)
24*	23.25	20.00	98.07	27.95	2180.0
(600)	(590.6)	(508.0)	(2491.0)	(709.9)	(991.0)

Class 300					
Size NPS (DN)	A	B	C	D	Weight Lbs (Kg)
1/2	0.50	5.50	8.23	3.87	7.0
(15)	(12.7)	(139.7)	(209.0)	(98.3)	(3.2)
3/4	0.75	6.00	8.43	4.87	7.9
(20)	(19.1)	(152.4)	(214.1)	(123.7)	(3.6)
1	1.00	6.50	11.02	7.00	16.3
(25)	(25.4)	(165.1)	(279.9)	(177.8)	(7.4)
1-1/2	1.50	7.50	13.30	7.87	30.8
(40)	(38.1)	(190.5)	(337.8)	(199.9)	(14.0)
2	2.00	8.5	14.92	7.87	50.6
(50)	(50.8)	(215.9)	(379.0)	(199.9)	(23.0)
2-1/2	2.50	9.50	16.95	7.87	68.0
(65)	(63.5)	(241.3)	(430.5)	(199.9)	(31.0)
3	3.00	11.13	18.39	8.82	88.0
(80)	(76.2)	(282.7)	(467.1)	(224.0)	(40.0)
4	4.00	12.00	21.38	9.84	123.0
(100)	(101.6)	(304.8)	(543.1)	(249.9)	(56.0)
6	6.00	15.88	29.57	13.98	238.0
(150)	(152.4)	(403.4)	(751.1)	(355.1)	(108.0)
8	8.00	16.50	38.50	15.75	398.0
(200)	(203.2)	(419.1)	(977.9)	(400.1)	(181.0)
10	10.00	18.00	46.61	17.72	568.0
(250)	(254.0)	(457.2)	(1183.9)	(450.1)	(258.0)

Class 300					
Size NPS (DN)	A	B	C	D	Weight Lbs (Kg)
12	12.00	19.75	53.82	19.69	827.0
(300)	(304.80)	(501.7)	(1367.0)	(500.1)	(376.0)
14*	13.25	30.00	60.12	22.05	1184.0
(350)	(336.6)	(762.0)	(1527.1)	(560.1)	(538.0)
16*	15.25	33.00	57.25	24.80	2053.0
(400)	(387.4)	(838.2)	(1454.2)	(629.9)	(931.0)
18*	17.00	36.00	74.28	27.95	2370.0
(450)	(431.8)	(914.4)	(1886.7)	(709.9)	(1075.0)
20*	19.00	39.00	84.10	31.50	2919.0
(500)	(482.6)	(990.6)	(2136.1)	(800.1)	(1324.0)
24*	23.00	45.00	98.85	31.50	4674.0
(600)	(590.6)	(1143.0)	(2510.8)	(800.1)	(2120.0)

Class 600					
Size NPS (DN)	A	B	C	D	Weight Lbs (Kg)
2	2.00	11.50	14.76	7.87	75.0
(50)	(50.8)	(292.1)	(374.9)	(199.9)	(34.0)
3	3.00	14.00	18.58	9.84	130.0
(80)	(76.2)	(355.6)	(471.9)	(249.9)	(59.0)
4	4.00	17.00	19.45	13.98	227.0
(100)	(101.6)	(431.8)	(494.0)	(355.1)	(103.0)
6	6.00	22.00	28.03	19.69	462.0
(150)	(152.4)	(558.8)	(712.0)	(500.1)	(210.0)
8	7.87	26.00	40.03	19.69	761.0
(200)	(199.9)	(660.4)	(1016.8)	(500.1)	(346.0)
10	9.75	31.00	49.02	22.05	1232.0
(250)	(247.7)	(787.4)	(1245.1)	(560.1)	(560) (G)
12	11.75	33.00	54.20	24.80	1665.0
(300)	(298.5)	(838.2)	(1376.7)	(629.9)	(757) (G)

Class 900					
Size NPS (DN)	A	B	C	D	Weight Lbs (Kg)
2	1.85	14.50	17.72	11.02	154.3
(50)	(47)	(368)	(450)	(280)	(70)
2-1/2	2.25	16.50	18.50	11.02	174.2
(65)	(57)	(419)	(470)	(280)	(79)
3	2.83	15.00	22.05	12.40	202.8
(80)	(72)	(381)	(560)	(315)	(92)
4	3.85	18.00	25.59	13.98	341.7
(100)	(98)	(457)	(650)	(355)	(160) (G)
6	5.75	24.00	35.04	19.69	661.4
(150)	(146)	(610)	(890)	(500)	(304) (G)
8	7.48	29.00	42.52	24.80	1102.3
(200)	(190)	(737)	(1080)	(630)	(500)
10	9.37	33.00	55.12	24.80	1719.6
(250)	(238)	(838)	(1400)	(630)	(788) (G)
12	11.10	38.00	62.99	24.80	2645.6
(300)	(282)	(965)	(1600)	(630)	(1206) (G)

Class 1500					
Size NPS (DN)	A	B	C	D	Weight Lbs (Kg)
2	1.85	14.50	17.72	11.02	154.3
(50)	(47)	(368)	(450)	(280)	(70)
2-1/2	2.25	16.50	18.50	11.02	174.2
(65)	(57)	(419)	(470)	(280)	(79)
3	2.72	18.50	27.56	13.98	326.3
(80)	(69)	(470)	(700)	(355)	(148)
4	3.62	21.50	33.46	19.69	529.1
(100)	(92)	(546)	(850)	(500)	(240)
6	5.35	27.75	43.31	24.80	1355.8
(150)	(136)	(705)	(1100)	(630)	(615)
8	6.96	32.75	45.28	27.95	1918.0
(200)	(177)	(832)	(1150)	(710)	(870)

* This size not normally stocked. Other sizes available upon request.

Note: Dimensions: Inches/Millimeters – Weights: Pounds/Kilograms. Dimensions are subject to change without notice.

II. SPECIAL APPLICATIONS – CRYOGENIC CONVENTIONAL PORT SIZES: 1/2" TO 24" (15MM TO 600MM) • CLASSES: 150 TO 600

Design and Manufacturing Standards

Valve Design: API 603/ASME B16.34

Flange Dimensions: ASME B16.5

Face to Face Dimensions: ASME B16.10

Tested in Accordance With: API 598

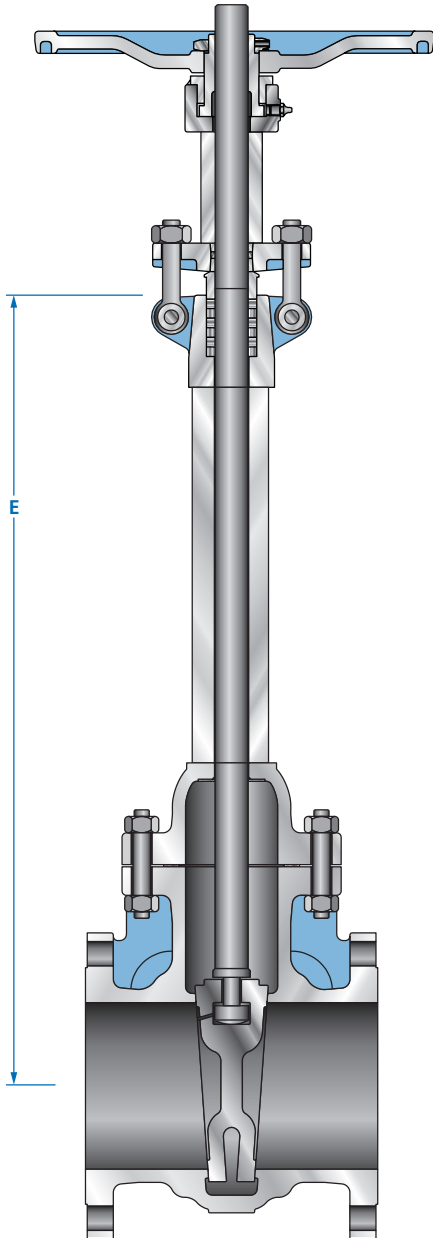

Special Design Cryogenic	
"E" Dimension (Standard Recommended Length)	
Size NPS (DN)	Extension Length
1/2	12
(15)	(305)
3/4	12
(20)	(305)
1	12
(25)	(305)
1-1/2	14
(40)	(356)
2	16
(50)	(406)
3	18
(80)	(457)
4	22
(100)	(559)
6	24
(150)	(610)
8	27
(200)	(686)
10	32
(250)	(813)
12	36
(300)	(914)

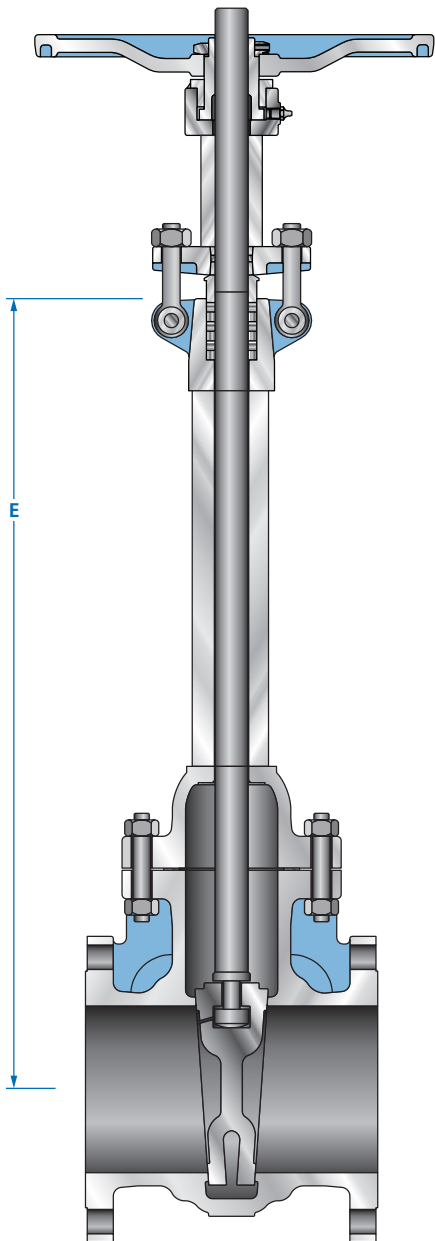

Special Design Cryogenic	
"E" Dimension (Standard Recommended Length)	
Size NPS (DN)	Extension Length
14	Sizes 14" and Up – As Per Cameron's Recommended Extension Length
(350)	
16	
(400)	
18	
(450)	
20	
(500)	
24	
(600)	

Note: Dimensions: Inches/Millimeters.
 Larger sizes available on request.
 Dimensions are subject to change without notice.

CAST STAINLESS STEEL GLOBE VALVES

SIZES: 1/2" TO 12" (15MM TO 300MM)
PRESSURE CLASS: 150 TO 1500

Typical Stainless Steel Globe Valve Expanded View

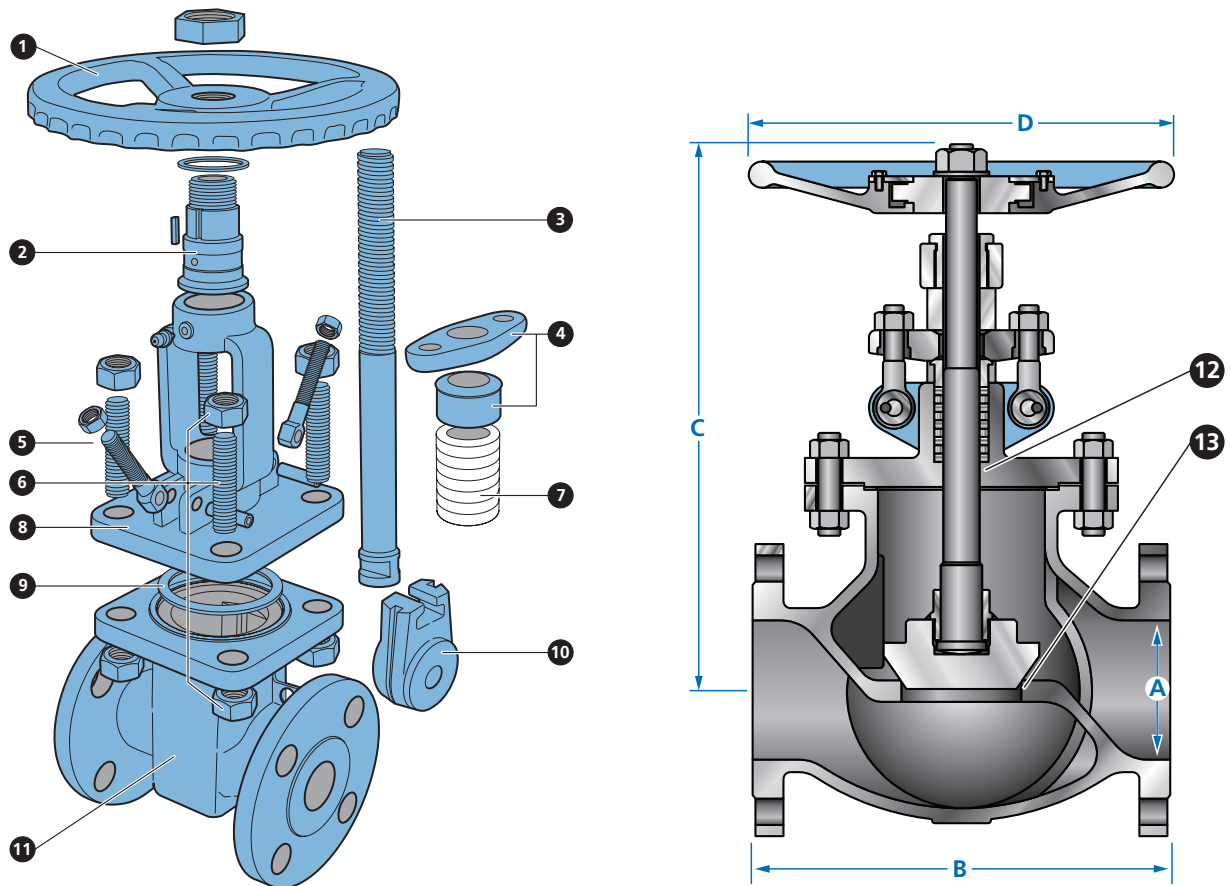

1. **Handwheel:** The nodular iron handwheels are well shaped and large enough to give ease of movement when operating the valve, even under maximum differential pressure.
2. **Yoke Sleeve:** The yoke sleeve is made from ductile iron with a high resistance to wear and a high melting point. It is screwed into the bonnet and properly sized to withstand the stresses which develop when opening and closing the valve.
3. **Stem:** The stem is stainless steel and is part of the trim. A ground backseat is provided to ensure perfectly tight seal to the stuffing box when the valve is fully open. The stem is attached to the disc by means of a threaded ring which allows the disc to rotate. The stem is ground to minimize friction and prevent damage to gland packing.
4. **Gland Bolts and Nuts:** The stainless steel gland bolts are of the eyebolt type which can be swung outward for ease of gland repacking. They are fixed to the bonnet by solid bolt pin tack welded.

5. **Gland and Flange:** The gland and flange are stainless steel and are normally supplied in two pieces. The contact surfaces between gland and gland flange have a spherical profile to permit the gland to descend parallel to the stem even if the eyebolts are not evenly tightened.
6. **Bonnet:** The bonnet is in stainless steel. It is machined to accept the yoke sleeve and incorporate the stuffing box dimensioned in accordance with the API standard and MSS SP standard.
7. **Disc:** The disc is part of the trim and is cast in stainless steel. It is normally supplied as a tapered type. Special attention is given to the seating face which is ground and lapped for a perfectly tight seal
8. **Packing*:** The packing is made with die formed graphite center rings with braided graphite top and bottom rings, or with teflon.
9. **Gasket*:** The gasket is made from graphite or teflon as specified based on service condition requirements.
10. **Bonnet Bolting:** Bonnet studs and nuts are manufactured from stainless steel to the relevant ASTM standard.
11. **Body:** The body is stainless steel and is carefully designed in all its details. The basic dimensions, i.e. wall thickness, face to face and flanges, comply with the relevant API and ANSI standards. The body to bonnet flange is circular. The sealing surfaces for connection to the bonnet are recessed in the 150-lb, 300-lb and 600-lb series. Bosses may be provided for drain taps and bypass piping.
12. **Bonnet Bushing (Integral):** The bonnet bushing or backseat is integrally machined from the cast stainless steel bonnet and forms part of the trim. Special attention is given to the seating face which is ground and lapped for a perfectly tight seal.
13. **Seat Rings (Integral):** The seat ring is cast integral in the body and is part of the trim. Special attention is given to the seating face, which is ground and lapped for a perfectly tight seal.

* *Recommended spare parts.*

I. CONVENTIONAL PORT SIZES: 1/2" TO 12"* • CLASSES: 150 TO 1500

Design and Manufacturing Standards

Valve Design: API 603/ASME B16.34

Flange Dimensions: ASME B16.5

Face to Face Dimensions: ASME B16.10

Tested in Accordance With: API 598

Class 150					
Size NPS (DN)	A	B	C	D	Weight Lbs (Kg)
1/2	0.50	4.25	7.84	4.00	6.8
(15)	(12.7)	(108.0)	(199.1)	(101.6)	(3.1)
3/4	0.75	4.63	7.84	4.00	7.7
(20)	(19.1)	(117.6)	(199.1)	(101.6)	(3.5)
1	1.00	5.00	9.93	4.75	11.7
(25)	(25.4)	(127.0)	(252.2)	(120.7)	(5.3)
1-1/2	1.50	6.50	9.60	4.75	18.7
(40)	(38.1)	(165.1)	(243.8)	(120.7)	(8.0)
2	2.00	8.00	13.03	7.09	39.6
(50)	(50.8)	(203.2)	(50.8)	(180.1)	(12.0)
2-1/2	2.50	8.50	12.70	7.09	58.0
(65)	(63.5)	(216.0)	(322.3)	(180.1)	(16.8)
3	3.00	9.50	15.04	8.82	59.0
(80)	(76.2)	(241.3)	(382.0)	(224.0)	(27.0)
4	4.00	11.50	16.38	11.02	99.0
(100)	(101.6)	(292.1)	(416.1)	(279.9)	(45.0)
6	6.00	16.00	17.80	12.40	163.0
(150)	(152.4)	(406.4)	(452.1)	(315.0)	(74.0)
8	8.00	19.50	22.72	15.75	288.0
(200)	(203.2)	(495.3)	(577.1)	(400.1)	(131.0)
10	10.00	24.50	26.25	19.68	463.0
(250)	(254.0)	(622.3)	(666.8)	(499.9)	(210.0)
12*	12.00	27.50	28.50	23.62	794.0
(300)	(304.8)	(698.5)	(723.9)	(600.0)	(360.0)

Class 300					
Size NPS (DN)	A	B	C	D	Weight Lbs (Kg)
1/2	0.50	6.00	7.84	4.00	8.6
(15)	(12.7)	(152.4)	(199.1)	(101.6)	(3.9)
3/4	0.75	7.00	7.84	4.00	10.6
(20)	(19.1)	(177.8)	(199.1)	(101.6)	(4.8)
1	1.00	8.00	9.93	4.75	15.6
(25)	(25.4)	(203.2)	(252.2)	(120.7)	(7.1)
1-1/2	1.50	9.00	10.15	7.08	28.6
(40)	(38.1)	(228.6)	(257.8)	(179.8)	(13.0)
2	2.00	11.50	14.56	7.87	48.4
(50)	(50.8)	(266.7)	(369.8)	(199.9)	(22.0)
2-1/2	2.50	11.50	14.41	8.82	75.0
(65)	(63.5)	(292.1)	(366.0)	(224.0)	(34.1)
3	3.00	12.50	18.22	11.02	88.0
(80)	(76.2)	(317.5)	(462.8)	(279.9)	(40.0)
4	4.00	14.00	20.35	12.40	145.0
(100)	(101.6)	(355.6)	(516.9)	(315.0)	(66.0)
6	6.00	17.50	28.03	15.74	262.0
(150)	(152.4)	(444.5)	(712.0)	(399.8)	(119.0)
8	8.00	22.00	30.80	19.69	455.0
(200)	(203.2)	(558.8)	(782.3)	(500.1)	(207.0)
10	10.00	24.50	34.35	27.56	882.0
(250)	(254.0)	(622.3)	(872.5)	(700.0)	(400.0)
12*	12.00	28.00	35.62	27.56	1213.0
(300)	(304.80)	(711.2)	(904.7)	(700.0)	(550.0)

Class 600					
Size NPS (DN)	A	B	C	D	Weight Lbs (Kg)
2	2.00	11.50	14.56	7.87	81.0
(50)	(50.8)	(292.1)	(369.8)	(199.9)	(30.0)
3	3.00	14.00	18.22	11.02	136.0
(80)	(76.2)	(355.6)	(462.8)	(279.9)	(60.0)
4	4.00	17.00	20.35	12.40	238.0
(100)	(101.6)	(431.8)	(516.9)	(314.9)	(95.0)
6	6.00	22.00	28.03	15.74	502.0
(150)	(152.4)	(558.8)	(718.8)	(399.8)	(190.0)

Class 600					
Size NPS (DN)	A	B	C	D	Weight Lbs (Kg)
8*	8.00	26.00	30.80	19.69	913.0
(200)	(203.2)	(660.4)	(782.32)	(500.1)	(360.0)
10*	10.00	31.00	34.35	27.56	1052.0
(250)	(254.0)	(787.4)	(872.5)	(700.0)	(478.0)
12*	12.00	33.00	35.62	27.56	1623.0
(300)	(304.8)	(838.2)	(904.7)	(700.0)	(736.0)

Class 900					
Size NPS (DN)	A	B	C	D	Weight Lbs (Kg)
2	1.85	14.50	18.28	11.02	163.1
(50)	(47)	(368)	(490)	(280)	(74)
2-1/2	2.25	16.50	19.69	12.40	211.6
(65)	(57)	(419)	(500)	(315)	(96)
3	2.83	15.00	21.65	13.98	185.2
(80)	(72)	(381)	(550)	(355)	(84)
4	3.85	18.00	23.62	15.75	390.2
(100)	(98)	(457)	(600)	(400)	(177)
6	5.75	24.00	33.31	23.62	687.8
(150)	(146)	(610)	(846)	(600)	(312)
12	11.10	38.00	57.09	35.43	4739.9
(300)	(282)	(965)	(1450)	(900)	(2150)

Class 1500					
Size NPS (DN)	A	B	C	D	Weight Lbs (Kg)
2	1.85	14.50	18.29	11.02	163.1
(50)	(47)	(368)	(490)	(280)	(74)
2-1/2	2.25	16.50	19.69	12.40	211.6
(65)	(57)	(419)	(500)	(315)	(96)
3	2.72	18.50	27.56	13.98	297.6
(80)	(69)	(470)	(700)	(355)	(135)

* This size not normally stocked. Other sizes available upon request.

Note: Dimensions: Inches/Millimeters – Weights: Pounds/Kilograms. Dimensions are subject to change without notice.

II. SPECIAL APPLICATIONS – CRYOGENIC CONVENTIONAL PORT SIZES: 1/2" TO 6" (15MM TO 150MM) • CLASSES: 150 TO 300

Design and Manufacturing Standards

Valve Design: API 603/ASME B16.34

Flange Dimensions: ASME B16.5

Face to Face Dimensions: ASME B16.10

Tested in Accordance With: API 598

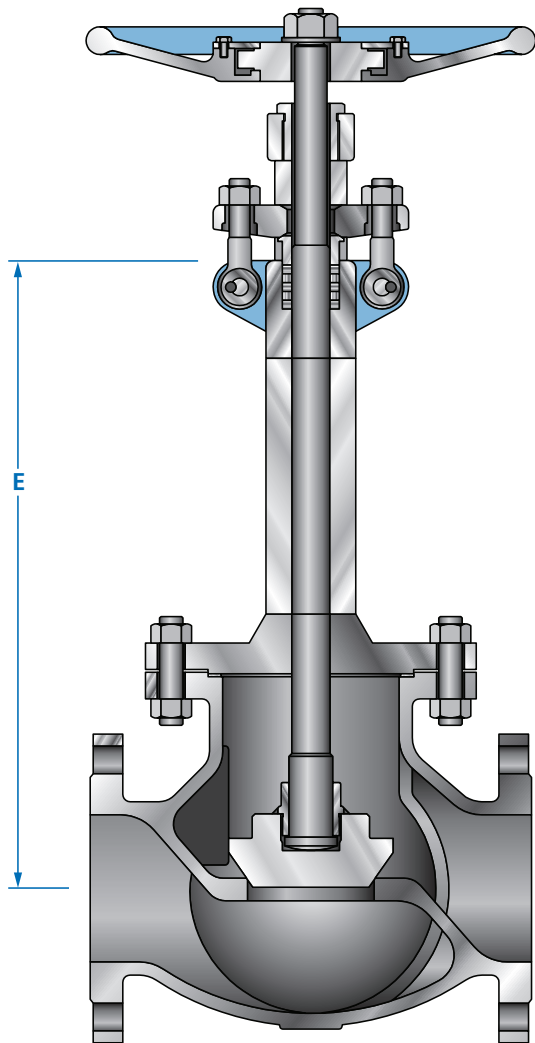

Special Design Cryogenic	
"E" Dimension (Standard Recommended Length)	
Size NPS (DN)	Extension Length
1/2	12
(15)	(305)
3/4	12
(20)	(305)
1	12
(25)	(305)
1-1/2	14
(40)	(356)
2	16
(50)	(406)
3	18
(80)	(457)
4	22
(100)	(559)
6	24
(150)	(610)
8	27
(200)	(686)
10	32
(250)	(813)
12	36
(300)	(914)

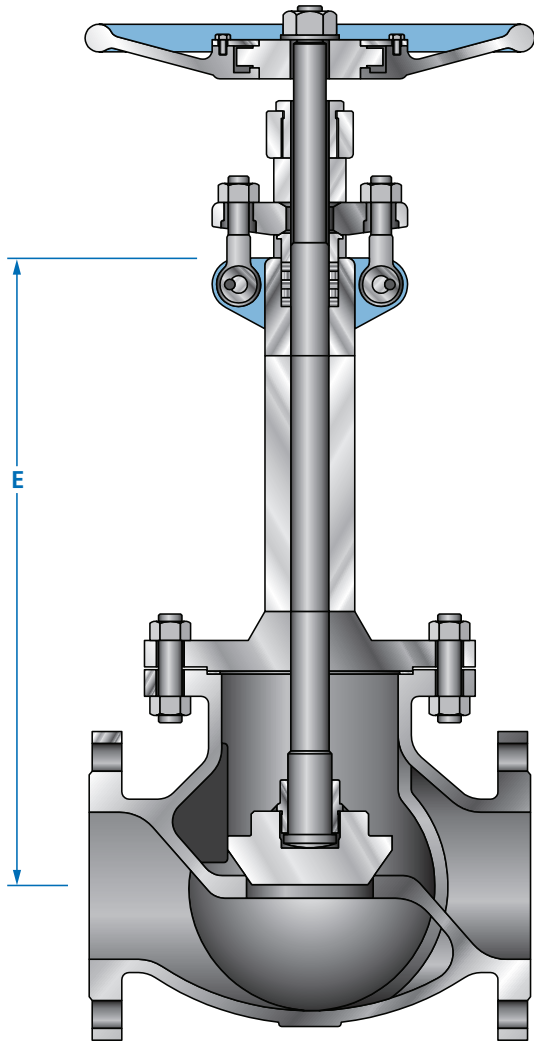

Special Design Cryogenic	
"E" Dimension (Standard Recommended Length)	
Size NPS (DN)	Extension Length
14	Sizes 14" and Up – As Per Cameron's Recommended Extension Length
(350)	
16	
(400)	
18	
(450)	
20	
(500)	
24	
(600)	

Note: Dimensions: Inches/Millimeters - Weights: Pounds/Kilograms. Larger sizes available on request. Dimensions are subject to change without notice.

CAST STAINLESS STEEL CHECK VALVES

SIZES: 1/2" TO 24" (15MM TO 600MM)
PRESSURE CLASS: 150 TO 1500

Typical Forged Steel Bolted Check Valve Expanded View

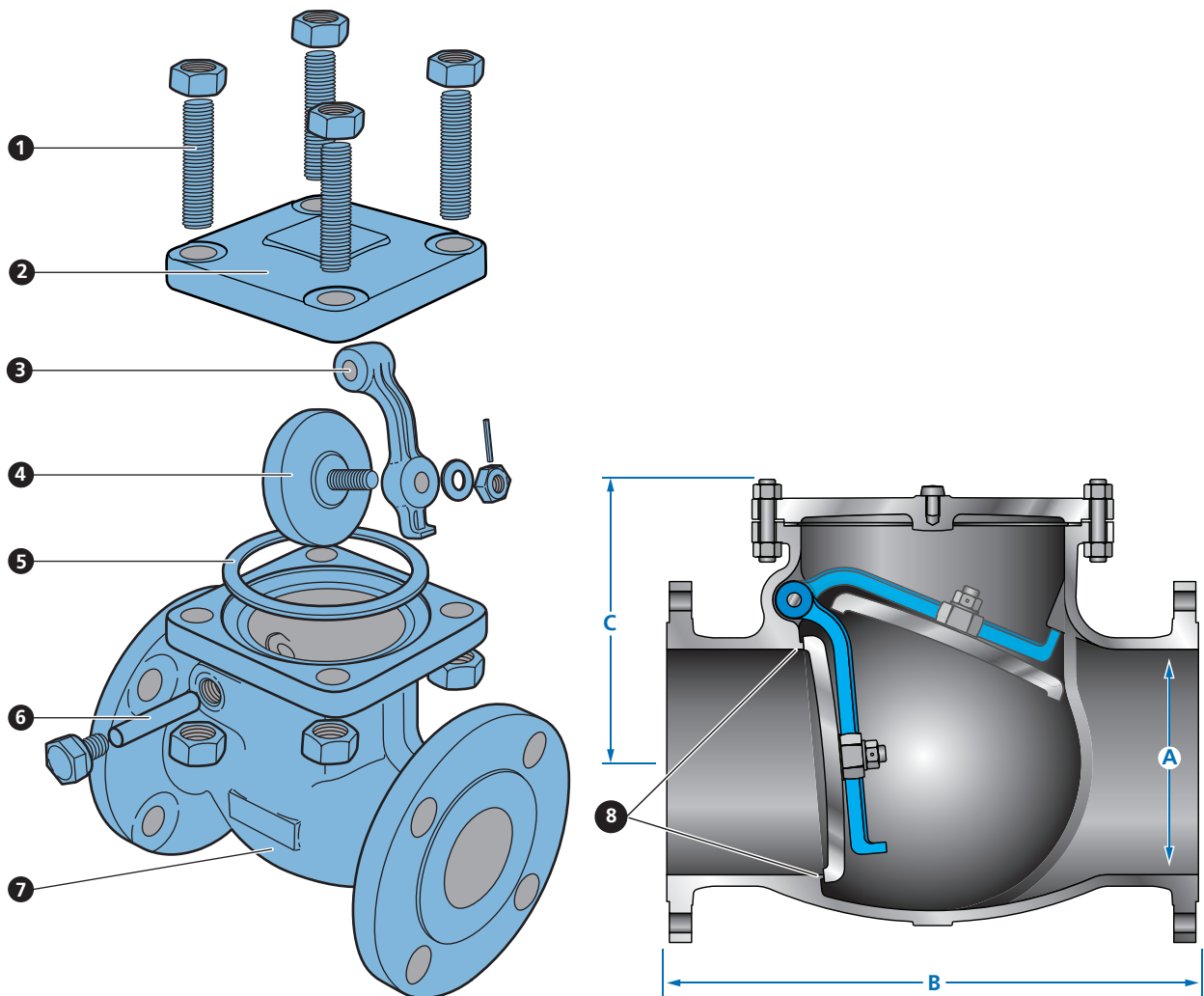

1. **Cap Bolting:** The cover studs and nuts are manufactured from stainless steel to the relevant ASTM standard.
2. **Cap:** The cap is cast stainless steel. The sealing surfaces for the connection to the body are flush in the 150-lb. class (sizes 1/2" - 1") and recessed in the 150-lb. class (sizes 1-1/2" and up), 300-lb. class and 600-lb. class valves.
3. **Hinge Arm:** The hinge is in forged stainless steel for small diameter and cast for 2" and up.
4. **Disc:** The disc is part of the trim. The back side has a threaded stud for attachment to the hinge arm with a stainless steel nut. To insure a strong connection, the nut is secured to the threaded stud by spot welding. The seating face is ground and lapped for a perfectly tight seal.

5. **Gasket***: The gasket is made from graphite or teflon as specified based on service condition requirements.
6. **Hinge Pin**: The hinge pin is part of the trim. It is stainless steel and is machined from round bar. The hinge pin is retained in the body by threaded plug and can be easily removed for maintenance of the valve.
7. **Body**: The body is cast stainless steel, carefully designed to keep pressure drops to a minimum. A wide opening on top of the body permits easy inspection and maintenance. The basic dimensions, i.e. wall thickness, face to face and flanges, comply with the relevant API and ANSI standards. Bosses may be provided for drain taps or bypass piping.
8. **Seat Ring (Integral)**: The seat ring is cast integral to the body and is part of the trim. Special attention is given to the seating face, which is ground and lapped for a perfectly tight seal.

* *Recommended spare parts.*

I. SWING CHECK VALVE CONVENTIONAL PORT SIZES: 1/2" TO 14" (15MM TO 350MM)* • CLASSES: 150 TO 1500

Design and Manufacturing Standards

Valve Design: API 603/ASME B16.34

Flange Dimensions: ASME B16.5

Face to Face Dimensions: ASME B16.10

Tested in Accordance With: API 598

Class 150				
Size NPS (DN)	A	B	C	Weight Lbs (Kg)
1/2	0.50	4.25	2.44	4.0
(15)	(12.7)	(108.0)	(62.0)	(1.8)
3/4	0.75	4.63	2.44	4.8
(20)	(19.1)	(117.6)	(62.0)	(2.2)
1	1.00	5.00	2.94	6.8
(25)	(25.4)	(127.0)	(74.7)	(3.1)
1-1/2	1.50	6.50	4.92	16.5
(40)	(38.1)	(165.1)	(125.0)	(7.5)
2	2.00	8.00	5.12	26.0
(50)	(50.8)	(203.2)	(130.0)	(12.0)
2-1/2	2.50	8.5	5.71	40.0
(65)	(63.5)	(216.0)	(145.0)	(18.0)
3	3.00	9.50	5.94	51.0
(80)	(76.2)	(241.3)	(150.9)	(23.0)
4	4.00	11.50	7.64	77.0
(100)	(101.6)	(292.1)	(194.1)	(35.0)
6	6.00	14.00	9.25	128.0
(150)	(152.4)	(355.6)	(235.0)	(58.0)
8	8.00	19.50	11.22	238.0
(200)	(203.2)	(495.3)	(285.0)	(108.0)
10	10.00	24.50	14.69	339.0
(250)	(254.0)	(622.3)	(373.1)	(154.0)
12	12.00	27.50	18.11	475.0
(300)	(304.80)	(698.5)	(460.0)	(216.0)
14*	13.25	31.00	19.80	620.0
(350)	(336.6)	(787.4)	(502.9)	(282.0)

Class 150				
Size NPS (DN)	A	B	C	Weight Lbs (Kg)
16	15.25	34.00	21.69	920.0
(400)	(387.4)	(863.6)	(550.9)	(418.0)
18*	17.25	38.50	22.05	1284.0
(450)	(438.2)	(977.9)	(560.1)	(582.0)
20*	19.25	38.50	24.80	1363.0
(500)	(489.0)	(977.9)	(629.9)	(618.0)
24*	23.25	51.00	27.95	2922.0
(600)	(590.6)	(1295.4)	(709.9)	(1325.0)

Class 300				
Size NPS (DN)	A	B	C	Weight Lbs (Kg)
1/2	0.50	6.00	2.52	5.1
(15)	(12.7)	(152.4)	(64.0)	(2.3)
3/4	0.75	7.00	2.56	7.5
(20)	(19.1)	(177.8)	(65.0)	(3.4)
1	1.00	8.50	3.23	10.8
(25)	(25.4)	(215.9)	(82.0)	(4.9)
1-1/2	1.50	9.50	5.51	23.5
(40)	(38.1)	(241.3)	(140.0)	(10.7)
2	2.00	10.50	5.94	40.0
(50)	(50.8)	(266.7)	(150.9)	(18.0)
3	3.00	12.50	4.48	79.0
(80)	(76.2)	(317.5)	(113.8)	(36.0)
4	4.00	14.00	8.66	121.0
(100)	(101.6)	(355.6)	(220.0)	(55.0)
6	6.00	17.5	12.83	235.0
(150)	(152.4)	(444.5)	(325.9)	(107.0)
8	8.00	21.00	14.80	352.0
(200)	(203.2)	(533.4)	(375.9)	(160.0)
10	10.00	24.50	16.18	535.0
(250)	(254.0)	(622.3)	(411.0)	(243.0)
12	12.00	28.00	19.13	768.0
(300)	(304.8)	(711.2)	(485.9)	(349.0)
14*	13.25	33.00	19.80	1233.0
(350)	(336.6)	(838.2)	(502.9)	(560.5)

Class 600				
Size NPS (DN)	A	B	C	Weight Lbs (Kg)
2	2.00	11.50	7.28	66.0
(50)	(50.8)	(292.1)	(184.9)	(30.0)
3	3.00	14.00	9.17	132.0
(80)	(76.2)	(355.6)	(232.9)	(60.0)
4	4.00	17.00	10.78	209.0
(100)	(101.6)	(431.8)	(273.8)	(95.0)
6	6.00	22.00	15.10	418.0
(150)	(152.4)	(558.8)	(383.5)	(190.0)
8	7.87	26.00	17.48	792.0
(200)	(199.9)	(660.4)	(444.0)	(360.0)
10	9.75	31.00	20.19	1052.0
(250)	(247.7)	(787.4)	(512.8)	(478.0)
12*	11.75	33.00	22.00	1544.0
(300)	(298.5)	(838.2)	(558.8)	(700.0)

Class 900				
Size NPS (DN)	A	B	C	Weight Lbs (Kg)
2	1.85	14.50	8.86	187.4
(50)	(47)	(368)	(225)	(85)
2-1/2	2.25	16.50	9.25	209.4
(65)	(57)	(419)	(235)	(95)
3	2.83	15.00	10.43	207.2
(80)	(72)	(381)	(265)	(94)
4	3.85	18.00	11.05	348.3
(100)	(98)	(457)	(280)	(158)
6	5.75	24.00	17.13	553.4
(150)	(146)	(610)	(435)	(251)
8	7.48	29.00	20.08	1146.1
(200)	(190)	(737)	(510)	(520)
10	9.37	33.00	22.05	1763.7
(250)	(238)	(838)	(560)	(800)
12	11.10	38.00	24.21	2425.1
(300)	(282)	(965)	(615)	(1100)

Class 1500				
Size NPS (DN)	A	B	C	Weight Lbs (Kg)
2	1.85	14.50	7.87	187.4
(50)	(47)	(368)	(200)	(85)
2-1/2	2.25	16.50	9.06	209.4
(65)	(57)	(419)	(230)	(95)
3	2.72	18.50	10.63	308.7
(80)	(69)	(470)	(270)	(140)
4	3.62	21.50	15.75	302.0
(100)	(92)	(546)	(400)	(137)
6	5.35	27.75	22.83	1067.0
(150)	(136)	(705)	(580)	(484)

* This size not normally stocked. Other sizes available upon request.

Note: Dimensions: Inches/Millimeters – Weights: Pounds/Kilograms. Dimensions are subject to change without notice.

FORGED GATE, GLOBE AND CHECK VALVES

SIZES: 1/4" TO 2" (6MM TO 50MM)

PRESSURE CLASS: 800 AND 1500

I. REGULAR PORT GATES – SOCKET WELD AND THREADED SIZES: 1/4" TO 2" (6MM TO 50MM) • CLASSES: 800 AND 1500

Design and Manufacturing Standards

Valve Design: API 602 and B16.34

Pipe Threads, General Purpose, Inch: ASME B1.20.1

Socket Welding and Threaded: ASME B16.11

Tested in Accordance With: API 598

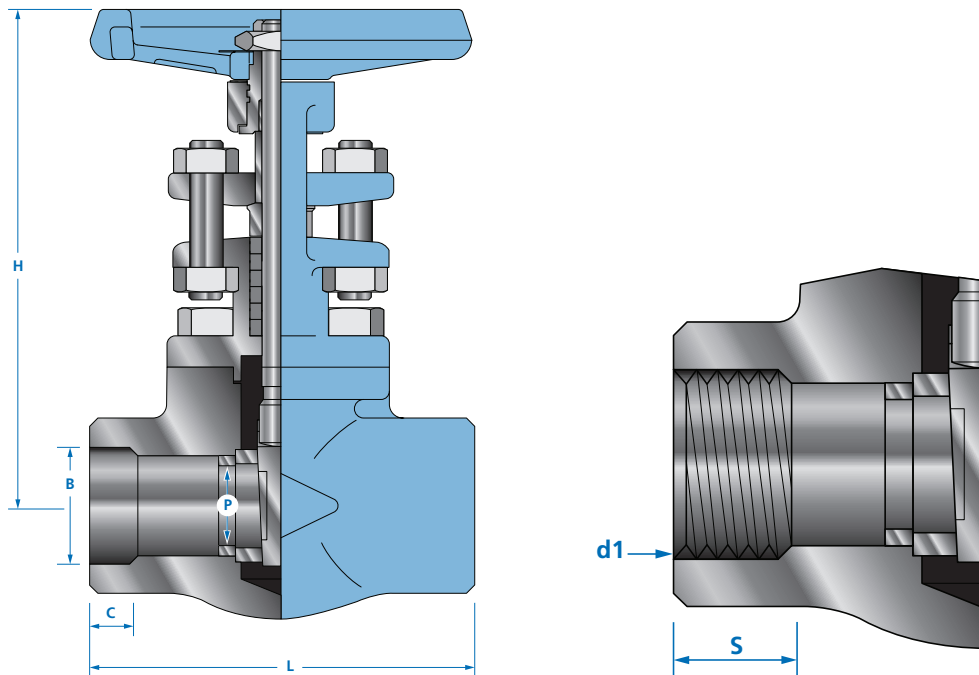

Class 800									
Size In. (DN)	H	L	W	P	End				Weight Lbs (Kg)
					B	C	d1	S	
1/4*	5.43	2.99	3.35	0.25	0.56	0.38	-	-	3.3
(6)*	(138)	(76)	(85)	(6)	(14)	(10)		-	(1.5)
3/8*	5.43	2.99	3.35	0.38	0.69	0.38	-	-	3.3
(10)*	(138)	(76)	(85)	(10)	(18)	(10)		-	(1.5)
1/2	5.43	2.99	3.35	0.38	0.86	0.38	1/2	0.54	3.3
(15)	(138)	(76)	(85)	(10)	(22)	(10)		(13.7)	(1.5)

Class 800									
Size In. (DN)	H	L	W	P	End				Weight Lbs (Kg)
					B	C	d1	S	
3/4	5.79	3.62	3.82	0.50	1.07	0.50	3/4	0.54	4.6
(20)	(147)	(92)	(97)	(13)	(27)	(13)		(13.7)	(2.1)
1	6.85	4.08	3.82	0.71	1.33	0.50	1	0.69	6.20
(25)	(174)	(104)	(97)	(18)	(34)	(13)		(17.52)	(2.8)
1-1/4	8.54	4.53	5.39	1.13	1.68	0.50	1-1/4	0.71	10.6
(30)	(217)	(115)	(137)	(29)	(43)	(13)		(18.0)	(4.8)
1-1/2	8.54	4.53	5.39	1.13	1.92	0.50	1-1/2	0.72	10.6
(40)	(217)	(115)	(137)	(29)	(49)	(13)		(18.3)	(4.8)
2	10.28	5.75	6.18	1.46	2.41	0.62	2	0.76	18.0
(50)	(261)	(146)	(157)	(37)	(61)	(16)		(19.3)	(8.2)

* Size available in socket weld design only.

Class 1500									
Size In. (DN)	H	L	W	P	End				Weight Lbs (Kg)
					B	C	d1	S	
1/2	5.79	3.62	3.82	0.38	0.86	0.38	1/2	0.54	4.6
(15)	(147)	(92)	(97)	(10)	(22)	(10)		(13.7)	(2.1)
3/4	6.14	4.09	3.82	0.50	1.07	0.50	3/4	0.54	6.4
(20)	(156)	(104)	(97)	(13)	(27)	(13)		(13.7)	(2.9)
1	8.15	4.53	5.39	0.71	1.33	0.50	1	0.69	11.0
(25)	(207)	(115)	(137)	(18)	(34)	(13)		(17.52)	(5.0)
1-1/4	9.69	5.75	6.18	1.13	1.68	0.50	1-1/4	0.71	18.0
(30)	(246)	(146)	(157)	(28)	(43)	(13)		(18.0)	(8.2)
1-1/2	9.69	5.75	6.18	1.13	1.92	0.50	1-1/2	0.72	18.0
(40)	(246)	(146)	(157)	(29)	(49)	(13)		(18.3)	(8.2)
2	11.93	8.27	6.18	1.48	2.41	0.62	2	0.76	26.2
(50)	(303)	(210)	(157)	(38)	(61)	(16)		(19.3)	(11.9)

Note: Pipe threads, general purpose, inch: B1.20.1. Socket welding and thread: B16.11.

Note: Dimensions: Inches/Millimeters – Weights: Pounds/Kilograms. Dimensions are subject to change without notice.

II. REGULAR PORT GLOBES – SOCKET WELD SIZES: 1/2" TO 2" (15MM TO 50MM) • CLASSES: 800 AND 1500

Design and Manufacturing Standards

Valve Design: API 602 and B16.34

Pipe Threads, General Purpose, Inch: ASME B1.20.1

Socket Welding and Threaded: ASME B16.11

Tested in Accordance With: API 598

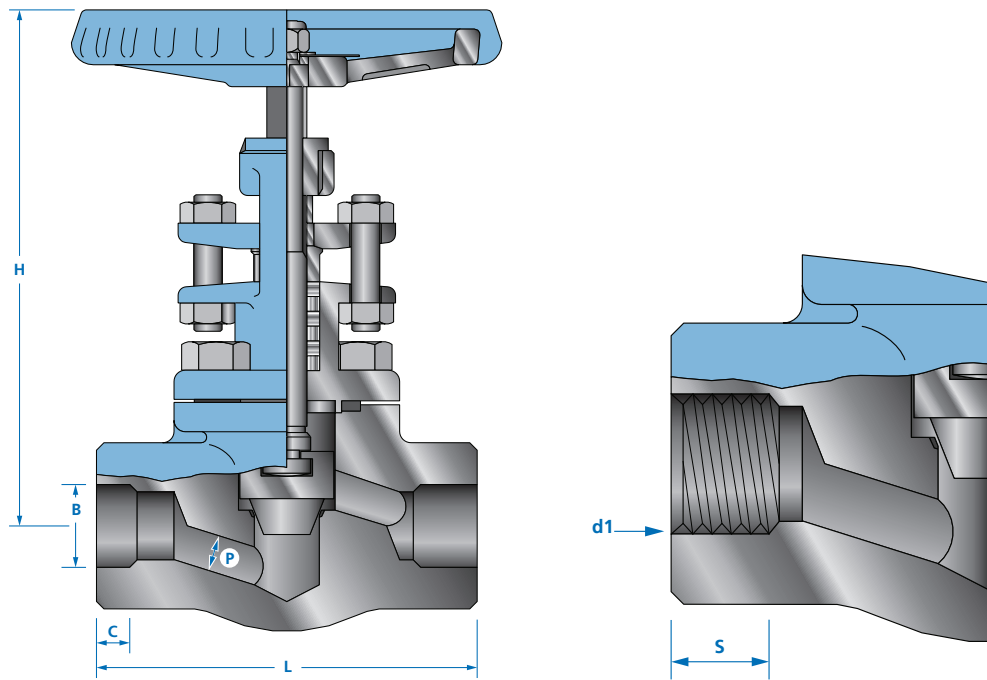

Class 800									
Size In. (DN)	H	L	W	P	End				Weight Lbs (Kg)
					B	C	d1 (NPT)	S	
1/2	5.67	2.99	3.35	0.37	0.86	0.38	1/2	0.54	3.3
(15)	(144.0)	(76)	(85)	(9.40)	(22)	(10)		(13.7)	(1.5)
3/4	6.06	3.62	3.82	0.50	1.07	0.50	3/4	0.54	4.8
(20)	(153.9)	(92)	(97)	(12.7)	(27)	(13)		(13.7)	(2.1)
1	6.97	4.09	3.82	0.69	1.33	0.50	1	0.69	6.2
(25)	(177.0)	(104)	(97)	(17.5)	(34)	(13)		(17.52)	(2.8)
1-1/4	8.86	5.51	5.39	1.16	1.68	0.50	1-1/4	0.71	12.3
(30)	(225.00)	(140)	(137)	(29.5)	(43)	(13)		(18.0)	(5.6)

Class 800									
Size In. (DN)	H	L	W	P	End				Weight Lbs (Kg)
					B	C	d1 (NPT)	S	
1-1/2	8.86	5.51	5.39	1.16	1.92	0.50	1-1/2	0.72	12.3
(40)	(225.00)	(140)	(137)	(29.5)	(49)	(13)		(18.3)	(5.6)
2	10.00	5.75	6.18	1.38	2.41	0.62	2	0.76	18.7
(50)	(254.0)	(146)	(157)	(35.1)	(61)	(16)		(19.3)	(8.5)

Class 1500									
Size In. (DN)	H	L	W	P	End				Weight Lbs (Kg)
					B	C	d1	S	
1/2	5.91	3.62	3.82	0.37	0.86	0.38	1/2	0.54	5.1
(15)	(150)	(92)	(97)	(9.40)	(22)	(10)		(13.7)	(2.3)
3/4	7.05	4.09	3.82	0.50	1.07	0.50	3/4	0.54	7.0
(20)	(179)	(104)	(97)	(12.7)	(27)	(13)		(13.7)	(3.2)
1	9.09	5.51	5.39	0.63	1.33	0.50	1	0.69	13.4
(25)	(231)	(140)	(137)	(16.0)	(34)	(13)		(17.52)	(6.1)
1-1/4	10.16	5.75	6.18	1.06	1.68	0.50	1-1/4	0.71	23.1
(30)	(258)	(146)	(157)	(26.9)	(43)	(13)		(18.0)	(10.5)
1-1/2	10.16	5.75	6.18	1.06	1.92	0.50	1-1/2	0.72	23.1
(40)	(258)	(146)	(157)	(26.9)	(49)	(13)		(18.3)	(10.5)
2	11.85	8.27	6.18	1.38	2.41	0.62	2	0.76	28.6
(50)	(301)	(210)	(157)	(35.1)	(61)	(16)		(19.3)	(13.0)

Note: Pipe threads, general purpose, inch: B1.20.1. Socket welding and thread: B16.11.

Note: Dimensions: Inches/Millimeters – Weights: Pounds/Kilograms. Dimensions are subject to change without notice.

III. SWING REGULAR PORT CHECKS – SOCKET WELD AND THREADED SIZES: 1/2" TO 2" (15MM TO 50MM) • CLASSES: 800 AND 1500

Design and Manufacturing Standards

Valve Design: API 602 and B16.34

Pipe Threads, General Purpose, Inch: ASME B1.20.1

Socket Welding and Threaded: ASME B16.11

Tested in Accordance With: API 598

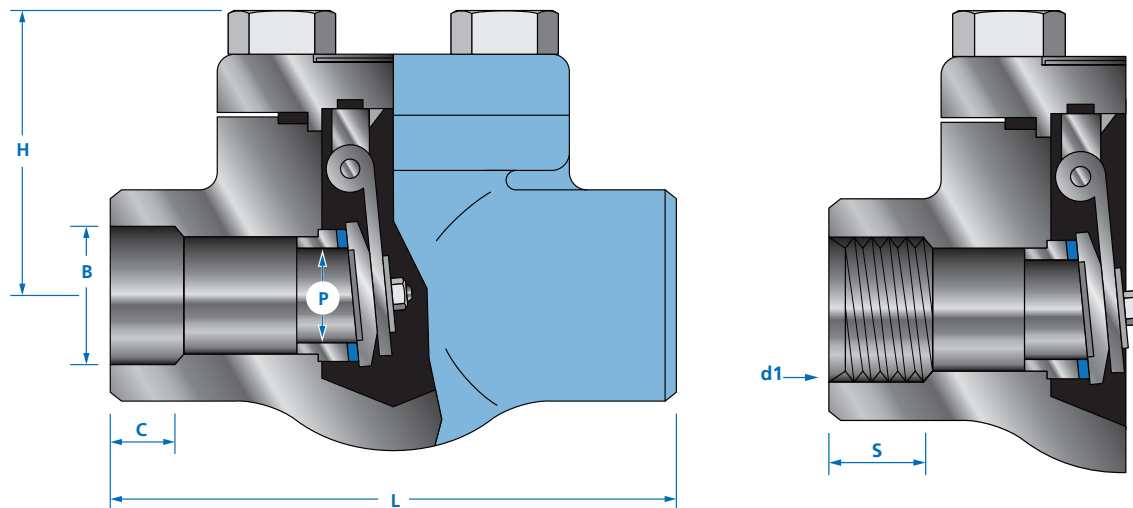

Class 800								
Size In. (DN)	H	L	P	End				Weight Lbs (Kg)
				B	C	d1 (NPT)	S	
1/2	1.81	2.99	0.36	0.86	0.38	1/2	0.54	2.2
(15)	(46)	(76)	(10)	(22)	(10)		(14)	(1.0)
3/4	2.20	3.62	0.50	1.07	0.50	3/4	0.54	3.3
(20)	(56)	(92)	(13)	(27)	(13)		(14)	(1.5)
1	2.56	4.09	0.71	1.33	0.50	1	0.69	4.4
(25)	(65)	(104)	(18)	(34)	(13)		(18)	(2.0)
1-1/4	2.95	4.53	1.13	1.68	0.50	1-1/4	0.71	9.0
(30)	(75)	(115)	(29)	(43)	(13)		(18)	(4.1)
1-1/2	2.95	4.53	1.13	1.92	0.50	1-1/2	0.72	9.0
(40)	(75)	(115)	(29)	(49)	(13)		(18)	(4.1)
2	3.94	5.75	1.46	2.41	0.62	2	0.76	14.1
(50)	(100)	(146)	(37)	(61)	(16)		(19)	(6.4)

Class 1500								
Size In. (DN)	H	L	P	End				Weight Lbs (Kg)
				B	C	d1	S	
1/2	2.20	3.62	0.38	0.86	0.38	1/2	0.54	3.3
(15)	(56)	(92)	(10)	(22)	(10)		(14)	(1.5)
3/4	2.56	4.09	0.50	1.07	0.50	3/4	0.54	4.4
(20)	(65)	(104)	(13)	(27)	(13)		(14)	(2.0)
1	2.95	4.53	0.71	1.33	0.50	1	0.69	9.0
(25)	(75)	(115)	(18)	(34)	(13)		(18)	(4.1)
1-1/4	3.94	5.75	1.13	1.68	0.50	1-1/4	0.71	14.1
(30)	(100)	(146)	(29)	(43)	(13)		(18)	(6.4)
1-1/2	3.94	5.75	1.13	1.92	0.50	1-1/2	0.72	14.1
(40)	(100)	(146)	(29)	(49)	(13)		(18)	(6.4)
2	4.92	8.27	1.46	2.41	0.62	2	0.76	21.6
(50)	(125)	(210)	(37)	(61)	(16)		(19)	(9.8)

Note: Pipe threads, general purpose, inch: B1.20.1. Socket welding and thread: B16.11.

Note: Dimensions: Inches/Millimeters – Weights: Pounds/Kilograms. Dimensions are subject to change without notice.

IV. LIFT REGULAR PORT CHECKS – SOCKET WELD AND THREADED SIZES: 1/2" TO 2" (15MM TO 50MM) • CLASS: 800 AND 1500

Design and Manufacturing Standards

Valve Design: API 602 and B16.34

Pipe Threads, General Purpose, Inch: ASME B1.20.1

Socket Welding and Threaded: ASME B16.11

Tested in Accordance With: API 598

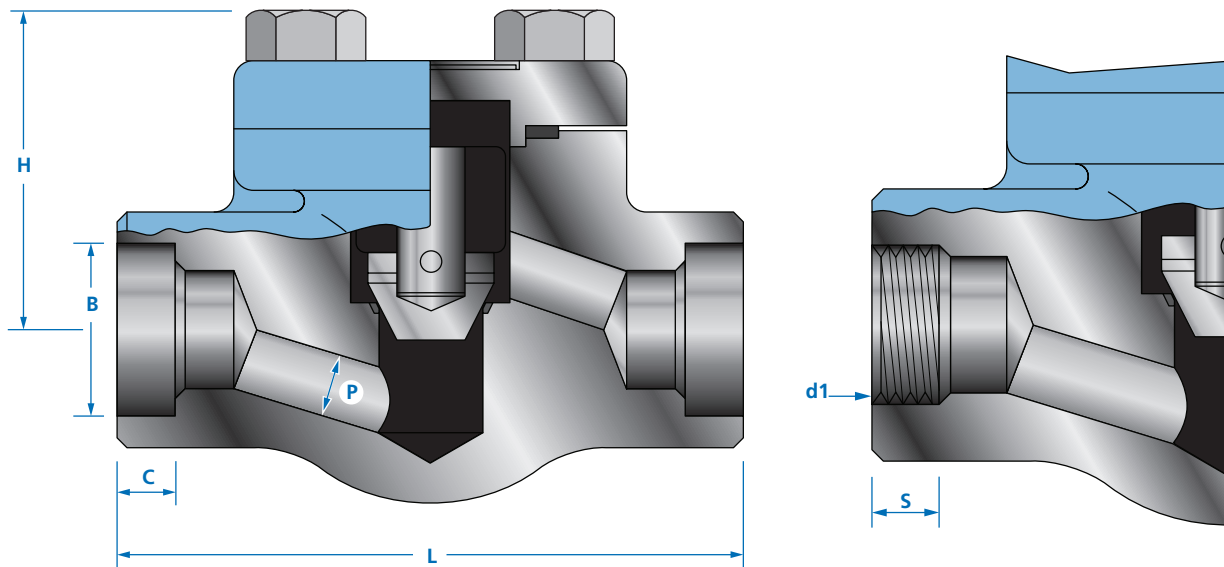

Class 800								
Size In. (DN)	H	L	P	End				Weight Lbs (Kg)
				B	C	d1 (NPT)	S	
1/2	1.81	2.99	0.38	0.86	0.38	1/2	0.54	2.2
(15)	(46)	(76)	(10)	(22)	(10)		(14)	(1.0)
3/4	2.20	3.62	0.50	1.07	0.50	3/4	0.54	3.3
(20)	(56)	(92)	(13)	(27)	(13)		(14)	(1.5)
1	2.56	4.09	0.69	1.33	0.50	1	0.69	4.4
(25)	(65)	(104)	(17.5)	(34)	(13)		(18)	(2.0)
1-1/4	2.95	5.51	1.16	1.68	0.50	1-1/4	0.71	9.0
(30)	(75)	(140)	(29.5)	(43)	(13)		(18)	(4.1)
1-1/2	2.95	5.51	1.16	1.92	0.50	1-1/2	0.72	9.0
(40)	(75)	(140)	(29.5)	(49)	(13)		(18)	(4.1)
2	3.94	5.75	1.38	2.41	0.62	2	0.76	14.1
(50)	(100)	(146)	(35.1)	(61)	(16)		(19)	(6.4)

Class 1500								
Size In. (DN)	H	L	P	End				Weight Lbs (Kg)
				B	C	d1	S	
1/2	2.20	3.62	0.37	0.86	0.38	1/2	0.54	3.3
(15)	(56)	(92)	(9.40)	(22)	(10)		(14)	(1.5)
3/4	2.56	4.09	0.50	1.07	0.50	3/4	0.54	4.4
(20)	(65)	(104)	(12.7)	(27)	(13)		(14)	(2.0)
1	2.95	5.51	0.63	1.33	0.50	1	0.69	9.0
(25)	(75)	(140)	(16.0)	(34)	(13)		(18)	(4.1)
1-1/4	3.94	5.75	1.06	1.68	0.50	1-1/4	0.71	14.1
(30)	(100)	(146)	(26.9)	(43)	(13)		(18)	(6.4)
1-1/2	3.94	5.75	1.06	1.92	0.50	1-1/2	0.72	14.1
(40)	(100)	(146)	(26.9)	(49)	(13)		(18)	(6.4)
2	4.92	8.27	1.38	2.41	0.62	2	0.76	21.6
(50)	(125)	(210)	(35.1)	(61)	(16)		(19)	(9.8)

Note: Pipe threads, general purpose, inch: B1.20.1. Socket welding and thread: B16.11.

Note: Dimensions: Inches/Millimeters - Weights: Pounds/Kilograms. Dimensions are subject to change without notice.

INSIDE DIAMETER DIMENSIONS

Size NPS (DN)	Inside Diameter Dimensions					
	Full Bore					
	150	300	600	900	1500	2500
1/2	0.50	0.50	0.50	0.50	0.50	0.44
(15)	(12.7)	(12.7)	(12.7)	(12.7)	(12.7)	(11.2)
3/4	0.75	0.75	0.75	0.69	0.69	0.56
(20)	(19.1)	(19.1)	(19.1)	(17.5)	(17.5)	(14.2)
1	1.00	1.00	1.00	0.87	0.87	0.75
(25)	(25.4)	(25.4)	(25.4)	(22.1)	(22.1)	(19.1)
1-1/4	1.25	1.25	1.25	1.12	1.12	1.00
(32)	(31.8)	(31.8)	(31.8)	(28.4)	(28.4)	(25.4)
1-1/2	1.50	1.50	1.50	1.37	1.37	1.12
(40)	(38.1)	(38.1)	(38.1)	(34.8)	(34.8)	(28.4)
2	2.00	2.00	2.00	1.87	1.87	1.50
(50)	(50.8)	(50.8)	(50.8)	(47.5)	(47.5)	(38.1)
2-1/2	2.50	2.50	2.50	2.25	2.25	1.87
(65)	(63.5)	(63.5)	(63.5)	(57.2)	(57.2)	(47.5)
3	3.00	3.00	3.00	2.87	2.75	2.25
(80)	(76.2)	(76.2)	(76.2)	(72.9)	(69.9)	(57.2)
4	4.00	4.00	4.00	3.87	3.62	2.87
(100)	(101.6)	(101.6)	(101.6)	(68.3)	(91.9)	(72.9)
5	5.00	5.00	5.00	4.75	4.37	3.62
(125)	(127.0)	(127.0)	(127.0)	(120.7)	(111.0)	(91.9)
6	6.00	6.00	6.00	5.75	5.37	4.37
(150)	(152.4)	(152.4)	(152.4)	(146.1)	(136.4)	(111.0)
8	8.00	8.00	7.87	7.50	7.00	5.75
(200)	(203.2)	(203.2)	(199.9)	(190.5)	(177.8)	(146.1)
10	10.00	10.00	9.75	9.37	8.75	7.25
(250)	(254.0)	(254.0)	(247.7)	(238.0)	(222.3)	(184.2)
12	12.00	12.00	11.75	11.12	10.37	8.62
(300)	(304.8)	(304.8)	(298.5)	(282.4)	(263.4)	(218.9)
14	13.25	13.25	12.87	12.25	11.37	9.50
(350)	(336.6)	(336.6)	(326.9)	(311.2)	(288.8)	(241.3)
16	15.25	15.25	14.75	14.00	13.00	10.87
(400)	(387.4)	(387.4)	(374.7)	(355.6)	(330.2)	(276.1)

Size NPS (DN)	Inside Diameter Dimensions					
	Full Bore					
	150	300	600	900	1500	2500
18	17.25	17.00	16.50	15.75	14.62	12.25
(450)	(438.2)	(431.8)	(419.1)	(400.1)	(371.3)	(311.2)
20	19.25	19.00	18.25	17.50	16.37	13.50
(500)	(489.0)	(482.6)	(463.6)	(444.5)	(415.8)	(342.9)
22	21.25	21.00	20.12	19.25	18.00	14.87
(550)	(539.8)	(533.4)	(511.0)	(489.0)	(457.2)	(377.7)
24	23.25	23.00	22.00	21.00	19.62	16.25
(600)	(590.6)	(584.2)	(558.8)	(533.4)	(498.3)	(412.8)
26	25.25	25.00	23.75	22.75	21.25	17.62
(650)	(641.4)	(635.0)	(603.3)	(577.9)	(539.8)	(447.5)
28	27.25	27.00	25.50	24.50	23.00	19.00
(700)	(692.2)	(685.8)	(647.7)	(622.3)	(584.2)	(482.6)
30	29.25	29.00	27.37	26.25	24.62	20.37
(750)	(743.0)	(736.6)	(695.2)	(666.8)	(625.3)	(517.4)

PRESSURE TEMPERATURE RATINGS

Temp. °F	Valve Class Working Pressures by Class - PSI					
	A351-CF8 • A351-CF3 • A182-F304					
	A351-CF8M • A351-CF3M • A182-F316					
	150	300	600	900	1500	2500
-20 to 100	275	720	1440	2160	3600	6000
	275	720	1440	2160	3600	6000
200	230	600	1200	1800	3000	5000
	240	620	1240	1660	3095	5160
300	205	540	1075	1615	2690	4480
	215	560	1120	1680	2795	4660
400	190	495	995	1490	2485	4140
	195	515	1030	1540	2570	4280
500	170	465	930	1395	2330	3880
	170	480	955	1435	2390	3980
600	140	440	885	1325	2210	3680
	140	450	905	1355	2255	3760
650	125	430	865	1295	2160	3600
	125	445	890	1330	2220	3700
700	110	420	845	1265	2110	3520
	110	430	865	1295	2160	3600
750	95	415	825	1240	2065	3440
	95	425	845	1270	2110	3520
800	80	405	810	1215	2030	3380
	80	415	830	1245	2075	3460
850	65	395	790	1190	1980	3300
	65	405	810	1215	2030	3320
900	50	390	780	1165	1945	3240
	50	395	790	1180	1970	3280
950	35	380	765	1145	1910	3180
	30	385	775	1160	1930	3220
1000	20	355	710	1065	1770	2950
	20	365	725	1090	1820	3030
1050	20	325	650	975	1630	2715
	20	360	720	1080	1800	3000
1100	20	255	515	770	1285	2145
	20	325	645	965	1610	2685
1150	20	205	410	615	1030	1715
	20	275	550	825	1370	2285
1200	20	165	330	495	825	1370
	20	205	410	620	1030	1715
1250	20	135	265	400	670	1115
	20	180	365	545	910	1515
1300	20	115	225	340	565	945
	20	140	275	410	685	1145

Temp. °F	Valve Class Working Pressures by Class - PSI					
	A351-CF8 • A351-CF3 • A182-F304					
	A351-CF8M • A351-CF3M • A182-F316					
	150	300	600	900	1500	2500
1350	20	95	185	280	465	770
	20	105	205	310	515	860
1400	20	75	150	225	380	630
	20	75	150	225	380	630
1450	20	60	115	175	290	485
	20	60	115	175	290	485
1500	15	40	85	125	205	345
	10	40	85	125	205	345
Hydrostatic Test Pressures in Pounds Per Square Inch Gage						
Shell	425	1100	2175	3250	5400	9000
Seat	303	792	1584	2376	3960	6600

Temp. °C	Valve Class Working Pressures by Class - bar					
	A351-CF8 • A351-CF3 • A182-F304					
	A351-CF8M • A351-CF3M • A182-F316					
	150	300	600	900	1500	2500
-29 to 38	19.0	49.6	99.3	148.9	248.2	413.7
	19.0	49.6	99.3	148.9	248.2	413.7
100	15.7	40.9	81.7	122.6	204.3	340.4
	16.2	42.2	84.4	126.6	211.0	351.6
150	14.2	37.0	74.0	111.0	185.0	308.4
	14.8	38.5	77.0	115.5	192.5	320.8
200	13.2	34.5	69.0	103.4	172.4	287.3
	13.7	35.7	71.3	107.0	178.3	297.2
250	12.1	32.5	65.0	97.5	162.4	270.7
	12.1	33.4	66.8	100.1	166.9	278.1
300	10.2	30.9	61.8	92.7	154.6	257.6
	10.2	31.6	63.2	94.9	158.1	263.5
350	8.4	29.6	59.3	88.9	148.1	246.9
	8.4	30.3	60.7	91.0	151.6	252.7
375	7.4	29.0	58.1	87.1	145.2	241.9
	7.4	29.9	59.8	89.6	149.4	249.0
400	6.5	28.4	56.9	85.3	142.2	237.0
	6.5	29.4	58.9	88.3	147.2	245.3
425	5.5	28.0	56.0	84.0	140.0	233.3
	5.5	29.1	58.3	87.4	145.7	242.9
450	4.6	27.4	54.8	82.2	137.0	228.4
	4.6	28.8	57.7	86.5	144.2	240.4
500	2.8	26.5	53.0	79.5	132.4	220.7
	2.8	28.2	56.5	84.7	140.9	235.0

Temp. °C	Valve Class Working Pressures by Class - PSI					
	A351-CF8 • A351-CF3 • A182-F304					
	A351-CF8M • A351-CF3M • A182-F316					
	150	300	600	900	1500	2500
538	1.4	24.4	48.9	73.3	122.1	203.6
	1.4	25.2	50.0	75.2	125.5	208.9
550	1.4(a)	23.6	47.1	70.7	117.8	196.3
	1.4(a)	25.0	49.8	74.8	124.9	208.0
575	1.4(a)	20.8	41.7	62.5	104.2	173.7
	1.4(a)	24.0	47.9	71.8	119.7	199.5
600	1.4(a)	16.9	33.8	50.6	84.4	140.7
	1.4(a)	19.9	39.8	59.7	99.5	165.9
625	1.4(a)	13.8	27.6	41.4	68.9	114.9
	1.4(a)	15.8	31.6	47.4	79.1	131.8
650	1.4(a)	11.3	22.5	33.8	56.3	93.8
	1.4(a)	12.7	25.3	38.0	63.3	105.5
675	1.4(a)	9.3	18.7	28.0	46.7	77.9
	1.4(a)	10.3	20.6	31.0	51.6	86.0
700	1.4(a)	8.0	16.1	24.1	40.1	66.9
	1.4(a)	8.4	16.8	25.1	41.9	69.8
725	1.4(a)	6.8	13.5	20.3	33.8	56.3
	1.4(a)	7.0	14.0	21.0	34.9	58.2
750	1.4(a)	5.8	11.6	17.3	28.9	48.1
	1.4(a)	5.9	11.7	17.6	29.3	48.9
775	1.4(a)	4.6	9.0	13.7	22.8	38.0
	1.4(a)	4.6	9.0	13.7	22.8	38.0
816	1.0(a)	2.8	5.9	8.6	14.1	23.8
	1.0(a)	2.8	5.9	8.6	14.1	23.8
Hydrostatic Test Pressures in Pounds Per Square Inch Gage						
Shell	425	1100	2175	3250	5400	9000
Seat	303	792	1584	2376	3960	6600

FLANGE DIMENSIONS – ASME B16.5

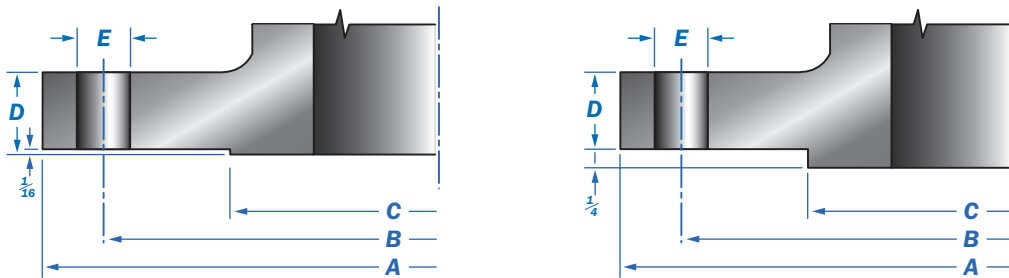

Flange Dimensions							
Class 150							
Size NPS DN	A	B	C	D	E	Bolt	
						Num.	Diam.
1/2	3.50	2.38	1.38	0.44	0.62	4	0.50
15	89	61	35	11	16		13
3/4	3.88	2.75	1.69	0.50 (0.44)	0.62	4	0.50
20	98	70	43	13 (11)	16		13
1	4.25	3.12	2.00	0.56 (0.44)	0.62	4	0.50
25	108	79	51	14 (11)	16		13
1-1/2	5.00	3.88	2.88	0.69 (0.56)	0.62	4	0.50
40	127	99	73	18 (14)	16		13
2	6.00	4.75	3.62	0.75 (0.62)	0.75	4	0.63
50	152	121	92	19 (16)	19		16
2-1/2	7.00	5.50	4.12	0.88 (0.69)	0.75	4	0.63
65	178	140	105	22 (18)	19		16
3	7.50	6.00	5.00	0.94 (0.75)	0.75	4	0.63
80	191	152	127	24 (19)	19		16
4	9.00	7.50	6.19	0.94	0.75	8	0.63
100	229	191	157	24	19		16
5	10.00	8.50	7.31	0.94	0.88	8	0.75
125	254	216	186	24	22		19
6	11.00	9.50	8.50	1.00	0.88	8	0.75
150	279	241	216	25	22		19
8	13.50	11.75	10.62	1.12	0.88	8	0.75
200	343	299	270	28	22		19
10	16.00	14.25	12.75	1.19	1.00	12	0.88
250	406	362	324	30	25		22

Flange Dimensions							
Class 150							
Size NPS DN	A	B	C	D	E	Bolt	
						Num.	Diam.
12	19.00	17.00	15.00	1.25	1.00	12	0.88
300	183	432	381	32	25		22
14	21.00	18.75	16.25	1.38	1.12	12	1.00
350	553	476	413	35	28		25
16	23.50	21.25	18.50	1.44	1.12	16	1.00
400	597	540	470	37	28		25
18	25.00	22.75	21.00	1.56	1.25	16	1.13
450	635	578	533	40	32		29
20	27.50	25.00	23.00	1.69	1.25	20	1.13
500	699	635	584	43	32		29
24	32.00	29.50	27.25	1.88	1.38	20	1.25
600	813	749	692	48	35		32

Flange Dimensions							
Class 300							
Size NPS DN	A	B	C	D	E	Bolt	
						Num.	Diam.
1/2	3.75	2.62	1.38	0.56	0.62	4	0.50
15	95	67	35	14	16		13
3/4	4.62	3.25	1.69	0.62	0.75	4	0.63
20	117	83	43	16	19		16
1	4.88	3.50	2.00	0.69	0.75	4	0.63
25	124	89	51	18	19		16
1-1/2	6.12	4.50	2.88	0.81	0.88	4	0.75
40	155	114	73	21	22		19
2	6.50	5.00	3.62	0.88	0.75	8	0.63
50	165	127	92	22	19		16
2-1/2	7.50	5.88	4.12	1.00	0.88	8	0.75
65	191	149	105	25	22		19
3	8.25	6.62	4.00	1.12	0.88	8	0.75
80	210	168	127	29	22		19

Flange Dimensions							
Class 300							
Size NPS DN	A	B	C	D	E	Bolt	
						Num.	Diam.
4	10.00	7.88	6.19	1.25	0.88	8	0.75
100	254	200	157	32	22		19
5	11.00	9.25	7.31	1.38	0.88	8	0.75
125	279	235	186	35	22		19
6	12.50	10.62	8.50	1.44	0.88	12	0.75
150	318	270	216	37	22		19
8	15.00	13.00	10.62	1.62	1.00	12	0.88
200	381	330	270	41	25		22
10	17.50	15.25	12.75	1.88	1.12	16	1.00
250	445	387	324	48	28		25
12	20.50	17.75	15.00	2.00	1.25	16	1.13
300	521	451	381	51	32		29
14	23.00	20.25	16.25	2.12	1.25	20	1.13
350	584	514	413	54	32		29
16	25.50	22.50	18.50	2.25	1.38	20	1.25
400	648	572	470	57	35		32
18	28.00	24.75	21.00	2.38	1.38	24	1.25
450	711	629	533	61	35		32
20	30.50	27.00	23.00	2.50	1.38	24	1.25
500	775	686	584	64	35		32
24	36.00	32.00	27.25	2.75	1.62	24	1.50
600	914	813	692	70	41		38

Flange Dimensions							
Class 600							
Size NPS DN	A	B	C	D	E	Bolt	
						Num.	Diam.
1/2	3.75	2.62	1.75	0.56	0.62	4	0.50
15	95	67	45	14	16		13
3/4	4.62	3.25	2.06	0.62	0.75	4	0.63
20	117	83	52	16	19		16

Flange Dimensions							
Class 600							
Size NPS DN	A	B	C	D	E	Bolt	
						Num.	Diam.
1	4.88	3.50	2.25	0.69	0.75	4	0.63
25	124	89	57	18	19		16
1-1/2	6.12	4.50	2.88	0.88	0.88	4	0.75
40	115	114	73	22	22		19
2	6.50	5.00	3.62	1.00	0.75	8	0.63
50	165	127	92	25	19		16
2-1/2	7.50	5.88	4.12	1.12	0.88	8	0.75
65	191	149	105	29	22		19
3	8.25	6.62	5.00	1.25	0.88	8	0.75
80	210	168	127	32	22		19
4	10.75	8.50	6.19	1.50	1.00	8	0.88
100	273	216	157	38	25		22
5	13.00	10.50	7.31	1.75	1.12	8	1.00
125	330	267	186	45	28		25
6	14.00	11.50	8.50	1.88	1.12	12	1.00
150	356	292	216	48	28		25
8	16.50	13.75	10.62	2.19	1.25	12	1.13
200	419	349	270	56	32		29
10	20.00	17.00	12.75	2.50	1.38	16	1.25
250	508	432	324	64	35		32
12	22.00	19.25	15.00	2.62	1.38	20	1.25
300	559	489	381	67	35		32
14	23.75	20.75	16.25	2.75	1.50	20	1.38
350	603	527	413	70	38		35
16	27.00	23.75	18.50	3.00	1.62	20	1.50
400	686	603	470	76	41		38
18	29.25	25.75	21.00	3.25	1.75	20	1.63
450	743	654	533	83	45		41
20	32.00	28.50	23.00	3.50	1.75	24	1.63
500	813	724	584	89	45		41
24	37.00	33.00	27.25	4.00	2.00	24	1.88
600	940	838	692	102	51		48

HOW TO ORDER CAMERON'S OIC CAST PRODUCTS

Figure Number

The figure number shown below identifies specific valve configuration details of Cameron's OIC valves such as valve type, pressure class, end connections, body/bonnet and trim materials, and special features.

Please specify end connections, body materials and trims not listed below.

When placing an order, please refer to the respective product section of the catalog for size availability. A detailed description must be included with any special orders.

S 151 - B W - U - G - * *

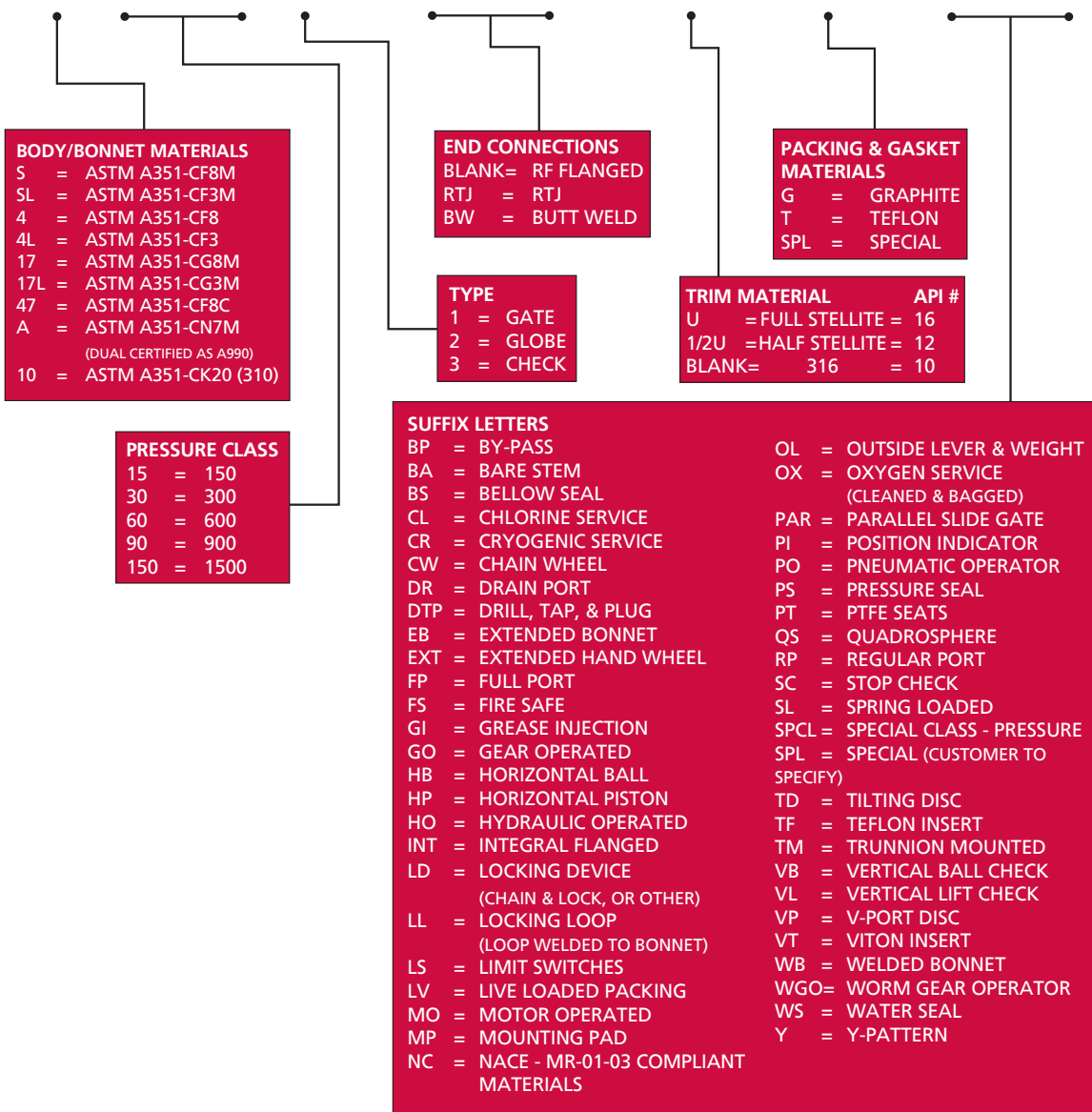

* For multiple modifications, continue adding letter designations with a hyphen between modifications.

Note: 800 Series valves are shown in separate forged stainless catalogue.

HOW TO ORDER CAMERON'S OIC FORGED PRODUCTS

Figure Number

The figure number shown below identifies specific valve configuration details of Cameron's OIC valves such as valve type, pressure class, end connections, body/bonnet and trim materials, and special features.

Please specify end connections, body materials and trims not listed below.

When placing an order, please refer to the respective product section of the catalog for size availability. A detailed description must be included with any special orders.

8GT-6L-SW-U-G-**-**

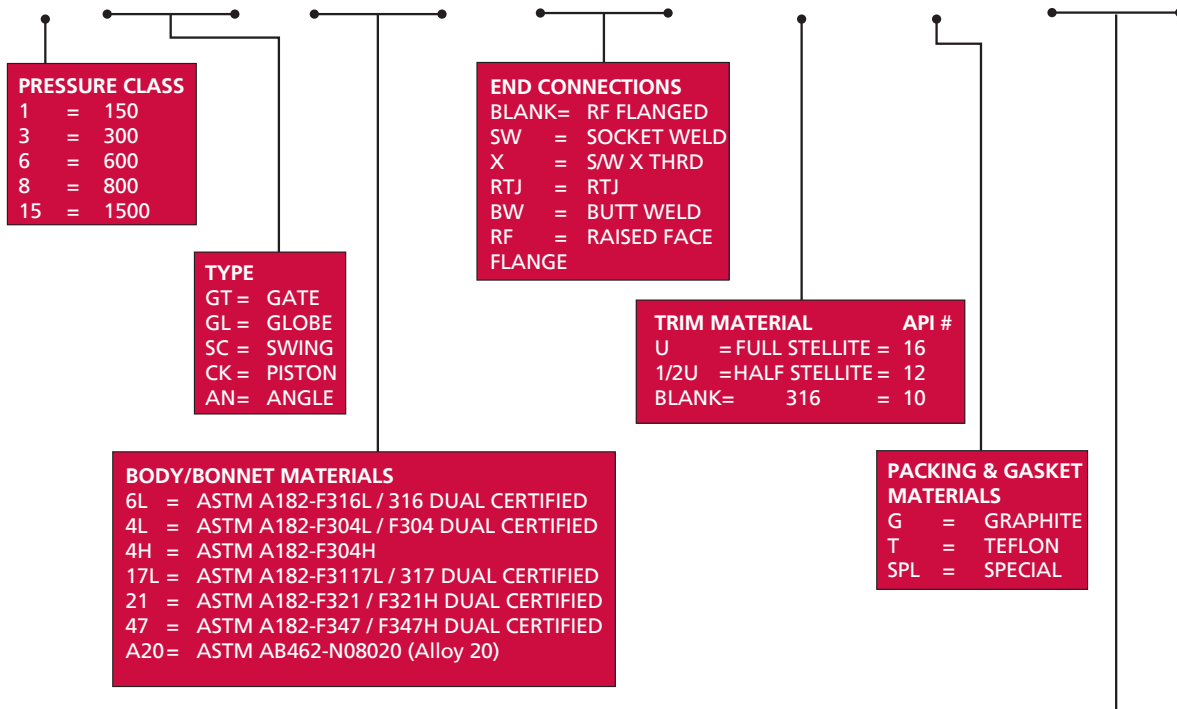

SUFFIX LETTERS		
BP	=	BY-PASS
BA	=	BARE STEM
BS	=	BELLOW SEAL
CL	=	CHLORINE SERVICE
CR	=	CRYOGENIC SERVICE
CW	=	CHAIN WHEEL
DR	=	DRAIN PORT
DTP	=	DRILL, TAP, & PLUG
EB	=	EXTENDED BONNET
EXT	=	EXTENDED HAND WHEEL
FP	=	FULL PORT
FS	=	FIRE SAFE
GI	=	GREASE INJECTION
GO	=	GEAR OPERATED
HB	=	HORIZONTAL BALL
HP	=	HORIZONTAL PISTON
HO	=	HYDRAULIC OPERATED
INT	=	INTEGRAL FLANGED
LD	=	LOCKING DEVICE (CHAIN & LOCK, OR OTHER)
LL	=	LOCKING LOOP (LOOP WELDED TO BONNET)
LS	=	LIMIT SWITCHES
LV	=	LIVE LOADED PACKING
MO	=	MOTOR OPERATED
MP	=	MOUNTING PAD
NC	=	NACE - MR-01-03 COMPLIANT MATERIALS
OL	=	OUTSIDE LEVER & WEIGHT
OX	=	OXYGEN SERVICE (CLEANED & BAGGED)
PAR	=	PARALLEL SLIDE GATE
PI	=	POSITION INDICATOR
PO	=	PNEUMATIC OPERATOR
PS	=	PRESSURE SEAL
PT	=	PTFE SEATS
QS	=	QUADROSPHERE
RP	=	REGULAR PORT
SC	=	STOP CHECK
SL	=	SPRING LOADED
SPCL	=	SPECIAL CLASS - PRESSURE
SPL	=	SPECIAL (CUSTOMER TO SPECIFY)
TD	=	TILTING DISC
TF	=	TEFLON INSERT
TM	=	TRUNNION MOUNTED
VB	=	VERTICAL BALL CHECK
VL	=	VERTICAL LIFT CHECK
VP	=	V-PORT DISC
VT	=	VITON INSERT
WB	=	WELDED BONNET
WGO	=	WORM GEAR OPERATOR
WS	=	WATER SEAL
Y	=	Y-PATTERN

INDUSTRY STANDARDS TYPICALLY USED IN VALVE MANUFACTURING

(For Reference Only)

ISO 9001: 2000
 RWTUV had approved NEWCO for design, manufacture, sales, & service of industrial valves under certificate registration number #05-1026

American Petroleum Institute (API)

API RP 574 (1998) - Inspection practices for piping system components
 API 589 (1998) - Fire test for evaluation of valve stem packing
 API RP 591 (2003) - Process valve qualification procedure
 API 594 (2004) - Check valves-flanged, lug, wafer & buttwelding
 API 597 (1981) - Steel venturi gate valves, flanged, buttwelding ends
 API 598 (2004) - Valve inspection & testing
 API 599 (2002) - Metal plug valves - flanged, welding ends
 API 601 (1988) - Metallic gaskets for raised-face pipe flanges & flanged connections (double-jacketed corrugated & spiral wound)
 API 600 (2001) - Bolted bonnet steel gate valves for petroleum & natural gas industries "ISO adoption from ISO 10434"
 API 602 (2005) - Steel gate, globe, & check valves for sizes DN100 and smaller for the petroleum & natural gas industries
 API 603 (2001) - Corrosion-resistant, bolted bonnet gate valves-flanged & buttweld ends
 API 604 (1981) - Ductile iron gate valves, flanged ends
 API 605 (1988) - Large-diameter carbon steel flanges (nominal pipe sizes 26" through 60", classes 75, 150, 300, 400, 600, & 900 (replaced by ANSI/ASME B16.47)
 API 606 (1989) - Compact steel gate valves, extended body (included in API 602) fire test for soft-seated quarter-turn valves "ISO adoption from ISO 10497-5 2004"
 API 607 (2005) - Fire test for soft-seated quarter-turn valves "ISO adoption from ISO 10497-5 2004"
 API 608 (2002) - Metal ball valves, flanged, threaded, & welding ends
 API 609 (2004) - Butterfly valves-double flanged, lug- & wafer-type
 API RP 941 (2004) - Steel for hydrogen service at elevated temperatures & pressures in petroleum refineries & petrochemical plants
 API RP 520 (2000), Part 1 - Sizing, selection & installation of pressure relieving devices in refineries
 API RP 520 (2003), Part 2 - Sizing, selection & installation of pressure relieving devices in refineries devices in refineries
 API Spec 6A (2005) - Specification for wellhead & christmas tree equipment
 API Spec 6D (2005) - Specifications for pipeline valves
 API Spec 14D (1994) - Specifications for wellhead surface safety valves & underwater safety valves for offshore service
 API 5B (2004) - Threading, gauging thread inspection of coring, tubing, & line pipe threads
 API 6AM (2003) - Material toughness
 API 6FA (1999) - Fire test for valves
 API 6FC (1999) - Fire test for valves with backseats
 API 6FD (1995) - Specification for fire test for check valves
 API Q1 (2003) - Specification for quality programs for the petroleum, petrochemical, & natural gas

American Society of Mechanical Engineers (ASME)

ASME Code (1997 addenda) - Boiler & pressure vessel code
 ASME A13.1 (1996) - Scheme for the identification of piping systems
 ASME B1.1 (2003) - Unified inch screw threads, UN, & UNR thread form
 ASME B1.5 (1997) - ACME screw threads
 ASME B1.7M (1984) - Nomenclature, definitions, & letter symbols for screw threads
 ASME B1.8 (1988) - Stub ACME screw threads
 ASME B1.12 (1987) - Class 5 interference - fit thread
 ASME B1.20.1 (1983) - Pipe threads, general purpose, inch
 ASME B1.20.3 (1976) - Dry-seal pipe threads, inch
 ANSI/ASME B16.1 (1998) - Cast iron pipe flanges & flanged fittings
 ANSI/ASME B16.5 (2003) - Pipe flanges & flanged fittings: NPS 1/2" through 24"
 ASME B16.9 (2003) - Factory made wrought steel buttwelding fittings
 ANSI/ASME B16.10 (2002) - Face-to-face & end-to-end dimensions of valves
 ASME B16.11 (2001) - Forged fittings, socket welding & threaded
 ASME B16.20 (1998) - Metallic gaskets for pipe flanges: ring joint spiral wound & jacketed
 ASME B16.21 (2005) - Non-metallic flat gaskets for pipe flanges
 ASME B16.25 (2003) - Butt-welding ends
 ANSI/ASME B16.33 (2002) - Manually operated metallic gas valves for use in gas piping systems up to 125 PSI (sizes NPS 1/2" through 2")
 ANSI/ASME B31.1 (2004) - Power piping
 ANSI/ASME B31.3 (2004) - Process piping
 ANSI/ASME B16.34 (2004) - Valves flanged, threaded & welding end
 ANSI/ASME B16.36 (1996) - Orifice flanges
 ANSI/ASME B16.38 (1985) - Large metallic valves for gas distribution (manually operated, NPS 2-1/2" through 12", 125 PSIG maximum)
 ANSI/ASME B16.42 (1998) - Ductile iron pipe flanges & flanged fittings: classes 150 & 300
 ANSI/ASME B16.47 (1996) - Large diameter steel flanges
 ANSI B17.1 (1967, R' 89) - Keys & keyseats
 ANSI B18.2.2 (1987) - Square & hex nuts
 ASME B31.4 (2002) - Pipeline transportation systems for liquid hydrocarbons & other ammonia & alcohols
 ANSI/ASME B31.8 (2003) - Gas transmission & distribution piping systems
 ANSI/ASME B36.10 (2004) - Welded & seamless wrought steel pipe
 ANSI/ASME B36.19 (2004) - Stainless steel pipe
 ANSI FCI-2 (1991) - Control valve seat leakage

American Society Non-destructive Test (ASNT)

ASNT-TC-1A (1996) - Recommended practice no. SNT-TC-1A 1996

American Society for Testing and Materials (ASTM)

British Standards Institute (BS)

BS 1414 (1975, R' 91) - Gate, wedge & double disk valves: steel
 BS 1868 (1975, R' 91) - Check valves: steel
 BS 1873 (1975, R' 91) - Globe & check valves: steel
 BS 2080 (1989) obsolete - Flanged & buttweld end steel valves
 BS 5146 - (withdrawn) Replaced by BS 6755 p.1 steel valves testing (1986) & BS 6755 p.2 (1984)
 BS 5152 (1974, R' 91) - Globe & check: cast iron
 BS 5153 (1974, R' 91) - Check: cast iron
 BS 5159 (1974, R' 91) - Ball: cast iron & carbon steel
 BS 5160 (1974, R' 91) - Globe & check: steel
 BS 5163 (1986, R' 91) - Gate, wedge & double disk: cast iron
 BS 5351 (1986, R' 91) - Ball: steel
 BS 5352 (1986, R' 91) - Globe & check: steel
 BS 5755: Part 1 (1986, R' 91) - Specification for production pressure testing requirements
 BS 5840 (1980, R' 91) - Valve mating details for actuator operation
 BS 6364 (1984, R' 91) - Cryogenic
 BS 6683 (1985, R' 91) - Guide: installation & use of valves
 BS 6755: Part 2 (1987) - Specification for fire type-testing requirements
 BS EN 19 (1992) - Marking of general purpose industrial valves

Canadian Standards Association

B51-97 - Boiler, pressure vessel, & pressure piping code
 Z245.15-96 - Steel valves
 CAN3-z299.4-85 (reaffirmed 1997) - Quality assurance program - Category 4
 CAN3-z299.3-85 (reaffirmed 1997) - Quality assurance program - Category 3

International Organization for Standardization

ISO 5211/1 (2001) - Industrial valves- part-turn actuator attachments
 ISO 5211/2 (2001) - Part-turn valve actuator attachment-flange & coupling performance characteristics
 ISO 5211/3 (2001) - Part-turn valve actuator attachment-dimensions of driving components
 ISO 5752 (1982) - Metal valves for use in flanged pipe systems face-to-face & center-to-face dimensions
 ISO 9000 (2005) - Quality management systems and fundamentals & vocabulary
 ISO 10012-1 (1992) - Quality assurance requirements for measuring equipment

Manufacturers Standardization Society

SP-6 (2001) - Standard finishes for contact faces of pipe flanges & connecting-end flanges of valves & fittings
 SP-9 (r2005) - Spot facing for bronze, iron & steel flanges
 SP-25 (1998) - Standard marking system for valves, fittings, flanges & unions
 SP-42 (2004) - Class 150 corrosion resistant gate, globe, angle, & check valves with flanged & buttweld ends
 SP-44 (2001) - Steel pipeline flanges
 SP-45 (2003) - Bypass & drain connections
 SP-51 (2003) - Class 150/w corrosion resistant cast flanges & flanged fittings
 SP-53 (2002) - Quality standard for steel castings & forgings for valves, flanges, & fittings & other piping components: magnetic particle exam method
 SP-54 (2002) - Quality standard for steel castings for valves, flanges, & fittings and other piping components: radiographic examination method
 SP-55 (2001) - Quality standard for steel castings for valves, flanges other piping components-visual method for evaluation of surface irregularities
 SP-60 (2004) - Connecting flange joint between tapping sleeves & tapping valves
 SP-61 (2003) - Pressure testing of steel valves
 SP-65 (2004) - High pressure chemical industry flanges & threaded stubs for use with lens gaskets
 SP-67 (2000A) - Butterfly valves
 SP-69 (2003) - ANSI/MSS edition pipe hangers & supports, selection & application
 SP-70 (1998) - Cast iron gate valves, flanged & threaded ends
 SP-71 (1997) - Gray iron swing check valves, flanged & threaded ends
 SP-72 (1999) - Ball valves with flanged or butt-welding ends for general service
 SP-79 (2004) - Socket-welding reducer inserts
 SP-81 (2001) - Stainless steel, bonnetless, flanged knife gate valves
 SP-82 (1992) - Valve pressure testing methods
 SP-84 (1990) - Valves - socket welding & threaded ends
 SP-85 (2002) - Cast iron globe & angle valves, flanged & threaded ends
 SP-86 (2002) - Guidelines for metric data in standards for valves, flanges, fittings & actuators
 SP-88 (r2001) - Diaphragm valves
 SP-91 (1992) - Guidelines for manual operation of valves
 SP-92 (1999) - MSS valve user guide
 SP-93 (r2004) - Quality standard for steel castings & forgings for valves, flanges & fittings & other piping components- liquid penetrant exam method
 SP-94 (r2004) - Quality standard for ferritic & martensitic steel castings for valves, flanges, & fittings and other piping components - ultrasonic exam method
 SP-96 (r2005) - Guidelines on terminology for valves & fittings
 SP-98 (2001) - Protective coatings for the interior of valves, hydrants, & fittings
 SP-99 (r2005) - Instrument valves
 SP-101 (r2001) - Part-turn valve actuator attachment-flange and driving component dimensions & performance characteristics
 SP-102 (r2001) - Multi-turn valve actuator attachment: flange and driving component dimensions & performance characteristics
 SP-110 (1996) - Ball valves threaded, socket-welding, solder joint, grooved, & flared ends
 SP-117 (2002) - Bellows seals for globe & gate valves
 SP-118 (2002) - Compact steel globe and check valves-flanged, flangeless, threaded & welding ends (chemical & petroleum refinery service)
 SP-120 (2002) - Flexible graphite packing system for rising stem steel valves (design requirements)
 SP-121 (R2002) - Qualification testing methods for stem packing for rising stem steel valves

National Association of Corrosion Engineers (NACE) MR0175 (2005)

- Sulfide stress cracking resistant metallic materials for oil field equipment
 MR0103 (2005) - Materials resistant to sulfide stress cracking in corrosive petroleum refining environments